



# ORIGINAL INSTRUCTIONS

# TABLE OF CONTENTS

## Welcome to Lumberjack!

Dear Customer, Thank You for your purchase. Before using the product for the first time please be sure to read these instructions for use. They provide you with all information necessary for using the product safely and to ensure its long service life.

Closely observe all safety information in these instructions!

<b>General Power Tool Safety Warnings.....</b>	<b>01</b>
<b>Symbols .....</b>	<b>05</b>
<b>Machine Details and Product features.....</b>	<b>06</b>
<b>Operation.....</b>	<b>08</b>
<b>Maintenance and Cleaning.....</b>	<b>10</b>
<b>Lumberjack Guarantee.....</b>	<b>11</b>
<b>Declaration of Conformity.....</b>	<b>13</b>
<b>Parts List.....</b>	<b>14</b>
<b>Parts Diagram.....</b>	<b>15</b>

# GENERAL POWER TOOL SAFETY WARNINGS

**WARNING Read all safety warnings and all instructions.** Failure to follow the warnings and instructions may result in electric shock, fire and/or serious injury.

**Save all warnings and instructions for future reference.** The term "power tool" in the warnings refers to your electric (corded) power tool or battery operated (cordless) power tool.

## 1. Work area safety

**a) Keep work area clean and well lit.** Cluttered or dark areas invite accidents.

**b) Do not operate power tools in explosive atmospheres, such as in the presence of flammable liquids, gases or dust.** Power tools create sparks which may ignite the dust or fumes.

**c) Keep children and bystanders away while operating a power tool.** Distractions can cause you to lose control.

## 2. Electrical safety

**a) Power tool plugs must match the outlet. Never modify the plug in any way. Do not use any adapter plugs with grounded power tools.** Unmodified plugs and matching outlets will reduce risk of electric shock.

**b) Avoid body contact with grounded surfaces, such as pipes, radiators, ranges and refrigerators.** There is an increased risk of electric shock if your body is grounded.

**c) Do not expose power tools to rain or wet conditions.** Water entering a power tool will increase the risk of electric shock.

**d) Do not abuse the cord. Never use the cord for carrying, pulling or unplugging the power tool. Keep cord away from heat, oil, sharp edges or moving parts.** Damaged or entangled cords increase the risk of electric shock.

**e) When operating a power tool outdoors, use an extension cord suitable for outdoor use.** Use of a cord suitable for outdoor use reduces the risk of electric shock.

**f) If operating a power tool in a damp location is unavoidable, use a residual current device (RCD) protected supply.** Use of an RCD reduces the risk of electric shock.

## 3. Personal safety

**a) Stay alert, watch what you are doing and use common sense when operating a power tool. Do not use a power tool while you are tired or under the influence of drugs, alcohol or medication.** A moment of inattention while operating power tools may result in serious personal injury.

**b) Use personal protective equipment. Always wear eye protection.** Protective equipment such as dust mask, non-skid safety shoes, hard hat, or hearing protection used for appropriate conditions will reduce personal injuries.

**c) Prevent unintentional starting. Ensure the switch is in the off position before connecting to power source and/or battery pack, picking up or carrying the tool.** Carrying power tools with your finger on the switch or energising power tools that have the switch on invites accidents.

**d) Remove any adjusting key or wrench before turning the power tool on.** A wrench or a key left attached to a rotating part of the power tool may result in personal injury.

# GENERAL POWER TOOL SAFETY WARNINGS

**e) Do not overreach. Keep proper footing and balance at all times.** This enables better control of the power tool in unexpected situations.

**f) Dress properly. Do not wear loose clothing or jewellery. Keep your hair, clothing and gloves away from moving parts.** Loose clothes, jewellery or long hair can be caught in moving parts.

**g) If devices are provided for the connection of dust extraction and collection facilities, ensure these are connected and properly used.** Use of dust collection can reduce dust related hazards.

## 4. Power tool use and care

**a) Do not force the power tool. Use the correct power tool for your application.** The correct power tool will do the job better and safer at the rate for which it was designed.

**b) Do not use the power tool if the switch does not turn it on and off.** Any power tool that cannot be controlled with the switch is dangerous and must be repaired.

**c) Disconnect the plug from the power source and/or the battery pack from the power tool before making any adjustments, changing accessories, or storing power tools.** Such preventive safety measures reduce the risk of starting the power tool accidentally.

**d) Store idle power tools out of the reach of children and do not allow persons unfamiliar with the power tool or these instructions to operate the power tool.** Power tools are dangerous in the hands of untrained users.

**e) Maintain power tools. Check for misalignment or binding of moving parts, breakage of parts and any other condition that may affect the power tool's operation. If damaged, have the power tool repaired before use.** Many accidents are caused by poorly maintained power tools.

**f) Keep cutting tools sharp and clean.** Properly maintained cutting tools with sharp cutting edges are less likely to bind.

**g) Use the power tool, accessories and tool bits etc. in accordance with these instructions, taking into account the working conditions and the work to be performed.** Use of the power tool for operations different from those intended could result in a hazardous situation.

## 5. Service

**a) Have your power tool serviced by a qualified repair person using only identical replacement parts.** This will ensure that the safety of the power tool is maintained.

**b) If the replacement of the supply cord is necessary, this has to be done by the manufacturer or its agent in order to avoid a safety hazard.**

# GENERAL POWER TOOL SAFETY WARNINGS

## 6. Safety Warnings for Rotary Hammer

- a) **Always wear ear protectors.** Exposure to noise can cause hearing loss.
- b) **Always use auxiliary handles supplied with the tool.** Loss of control can cause personal injury.
- c) **Hold power tools by insulated gripping surfaces when performing an operation where the cutting accessory may contact hidden wiring or its own cord.** Cutting accessory contacting a "live" wire may make exposed metal parts of the power tool "live" and could give the operator an electric shock.
- d) Safety boots are recommended at all times especially when using the chisel actions.
- e) Proper safety gloves are also recommended.
- f) When using the chisel a dust mask is necessary because of the cement dust created by the action.
- g) Always check the walls and ceilings to avoid hidden power cables and pipes. A metal detector can be obtained from any good DIY store for this purpose.
- h) Use clamps or a vice to hold workpiece, if possible.
- I) This heavy duty high torque machine should not be used, while standing on a ladder.
- J) Before starting to work always check that the chisel or drill bit is properly locked in the chuck.
- k) Hold the tool firmly with both hands while working and you have a secure footing. The tool is more securely guided with both hands.

l) Wait until the machine has come to a standstill before placing it down. The insertion tool can become caught and lead to loss of control over the machine.

m) The screws in the machine can come loose easily, and causing a breakdown or accident. Check tightness of screw carefully before operation.

n) Do not touch the bit or parts close to the bit immediately after operation. They may be extremely hot and could burn your skin.

o) In cold weather or when the tool has not been used for a long time. Let the tool warm up for a while by operating it under no load. This will loosen up the lubrication.

p) Some materials can contain chemicals which may be toxic. Take caution to prevent dust inhalation and skin contact. Follow material supplier safety data.

### HEALTH ADVICE



**WARNING!** When drilling, sanding, sawing or grinding, dust particles will be produced. In some instances, depending on the materials you are working with, this dust can be particularly harmful to you (e.g. lead from old gloss paint).

You are advised to consider the risks associated with the materials you are working with and to reduce the risk of exposure. You should:  
-Work in a well-ventilated area.

-Work with approved safety equipment, such as dust masks that are specially designed to filter microscopic particles.

# GENERAL POWER TOOL SAFETY WARNINGS

## Double insulation:

The tool is double insulated. This means that all the external metal parts are electrically insulated from the mains power supply. This is done by placing insulation barriers between the electrical and mechanical components making it unnecessary for the tool to be earthed.

### Important note:

Be sure the supply is the same as the voltage given on the rating plate. The tool is fitted with a two-core cable and plug.

Remove the mains plug from socket before carrying out any adjustment or servicing.

### Torque limiter:

There is a clutch in your hammer drill. The torque limiter will actuate when a certain torque level is reached. The motor will disengage from the output shaft. When this happens, the bit will stop turning. As soon as the torque limiter actuates, release the trigger and remove the tool and bit immediately. This will help prevent premature wear of the tool.

## 7. Safety Warnings for Drill

**a)When using the electric hammer chisel only use bits that are configured with the correct slots for this chuck.**

**b)BEFORE STARTING** the operation, jog the chisel switch to make sure the chisel bit does not wobble or vibrate.

**c)MAKE SURE** the spindle has come to a complete stop before touching the chuck or attempting to change the chisel bit also beware that the bit will be hot, let it cool down before changing as it could burn and cause injury.

**e)ALWAYS MAKE SURE THE CHISEL IS FIRMLY SEATED IN THE HEX CHUCK** before starting the job in hand.

## 8. Safety Warnings for Vibration safety

This tool vibrates during use. Repeated or long-term exposure to vibration may cause temporary or permanent physical injury, particularly to the hands, arms and shoulders. To reduce the risk of vibration-related injury:

- Absorbs reaction force of drill bit at the moment of impact
- Improved operation with extremely low vibration
- Reduced strain over prolonged periods of use
- Working with a safer machine improves user confidence

# SYMBOLS AND POWER RATING CHART



**Danger! – Read the operating instructions to reduce the risk of injury.**



**Caution! Wear safety goggles.**



**Caution! Wear ear defenders. The impact of noise can cause damage to hearing.**

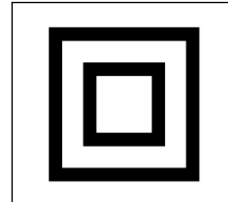

**Protection Class:  
Double Insulated.**



**Caution! Wear a dust mask.**

# MACHINE DETAILS AND PRODUCT FEATURES

## Machine Details

### Specifications:

Mains Voltage -	230V / 50Hz
Power -	1050W
No Load Speed -	0-1150rpm
Max. Impact Speed -	5100bpm
Impact Joules -	3.0J
Drilling Capacity –	
Max. In Steel -	13mm
Max. In Concrete -	26mm
Max. In Wood -	30mm
Chuck Type -	SDS-PLUS
Gross Weight -	3.6kg
Nett Weight -	3.3kg

### Package Contents:

- Rotary hammer
- Auxiliary handle
- Depth Gauge
- 8,10,12 X 145mm SDS Drill Bit
- 20 X 245mm SDS Point Chisel & SDS Flat Chisel
- 1 Spare Set of Carbon Brushes

## Intended Use

The machine is intended for hammer drilling in concrete, brick and stone as well as for light chiseling work. It is also suitable for drilling without impact in wood, metal, ceramic and plastic.

Other uses for the tool will lead to the damage of the tool and a series of dangers to the operator. This tool is intended for DIY home use or occasional professional use.

## Product Features

1. Variable speed switch
2. Lock –on button
3. Forward/reverse switch
4. Variable speed control knob
5. Drilling mode selector
6. Tool holder
7. Side handle
8. Depth stop

# MACHINE DETAILS AND PRODUCT FEATURES

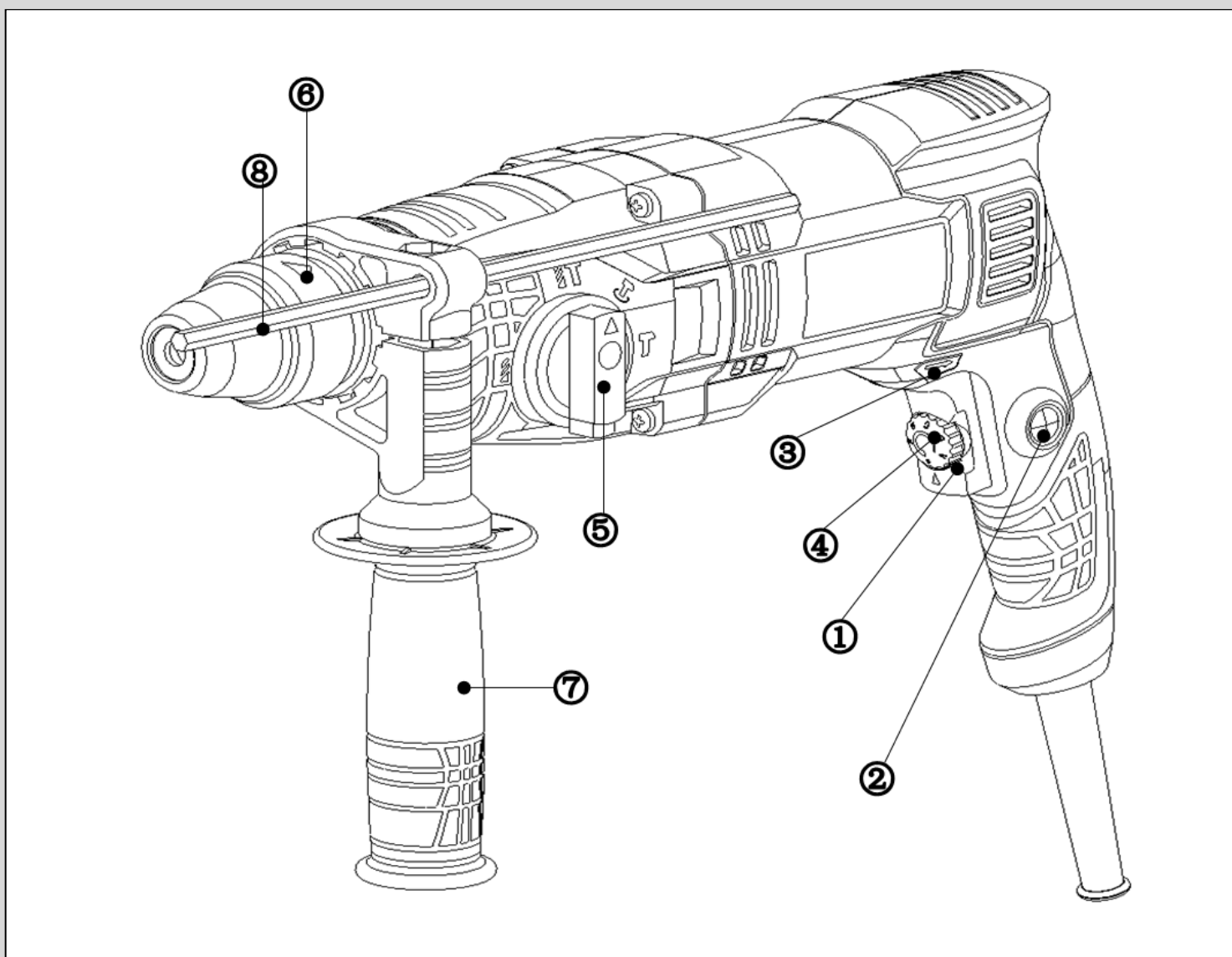

# OPERATION

## Operation

**Warning!** Before assembly, make sure that the tool is switched off and unplugged.

### Fitting the side handle and depth stop

- Turn the grip counterclockwise until you can slide the side handle(7) onto the front of the tool.
  - Rotate the side handle into the desired position.
- Insert the depth stop (8) into the mounting hole as shown. Set the depth stop to the desired position. The maximum drilling depth is equal to the distance between the tip of the drill bit and the front end of the depth stop.
- Tighten the side handle by turning the grip clockwise.

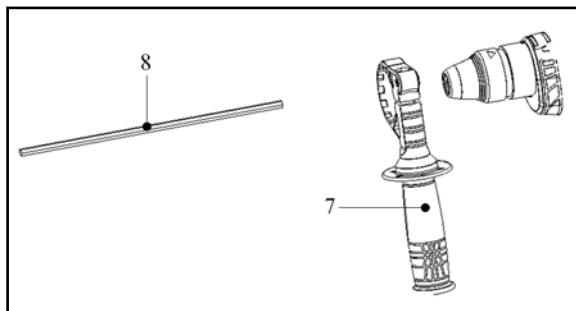

### Fitting an accessory

#### Insert the SDS-plus quick change chuck

- Clean and lightly grease the shank (9) end of the tool.
  - Insert the tool in twisting manner into the tool holder until it latches itself(6).
- Check the latching by pulling the tool.
- To remove the accessory, pull back the sleeve (10) and pull out the accessory.

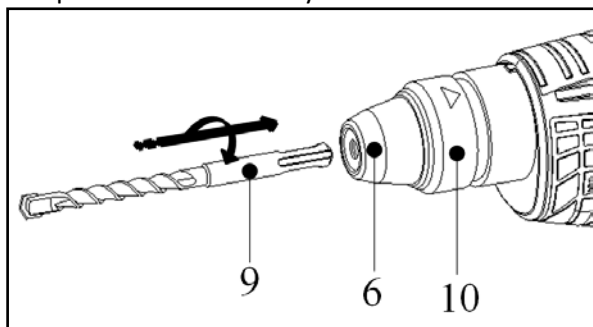

## Use

**Warning!** Let the tool work at its own pace. Do not overload.

**Warning!** Before drilling into walls, floors or ceilings, check for the location of wiring and pipes.

### Selecting the operating mode

The tool can be used in various operating modes. Press in the button (17) and rotate the drilling mode selector (5) towards the required position, as indicated by the symbols.

### Drilling

- For drilling in steel, wood and plastics, set the operating mode selector (5) to the  position.

### Hammer drilling

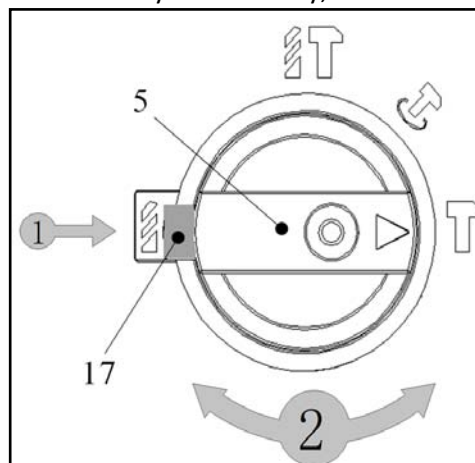

- For hammer drilling in masonry and concrete, set the operating mode selector (5) to the  position
- When hammering, the tool should not bounce and run smoothly. If necessary, increase the speed.



### Hammering

- For hammering with spindle lock, and for light chiseling and chipping, set the operating mode selector (5) to the **T** position.
- Make sure the forward/reverse switch is in the forward position.
- When changing from hammer drilling to chiseling, turn the chisel to the desired position. If resistance is felt during mode change, slightly turn the chisel to engage the spindle lock.

# OPERATION

- When hammering with spindle lock, the angle of the bit may be changed. Set the operating mode selector (5) to the  position, the angle of the bit may now be changed by rotating the tool holder (7). Set the operating mode selector (5) to the  position, before continuing.

## Selecting the direction of rotation

For drilling, and for chiseling, use forward (clockwise) rotation.

For removing a jammed drill bit, use reverse (counter clockwise) rotation.

- To select forward rotation, push the forward/reverse slider (3) to the left.

- To select reverse rotation, push the forward/reverse slider to the right.

**Warning !** Never change the direction of rotation while the motor is running.

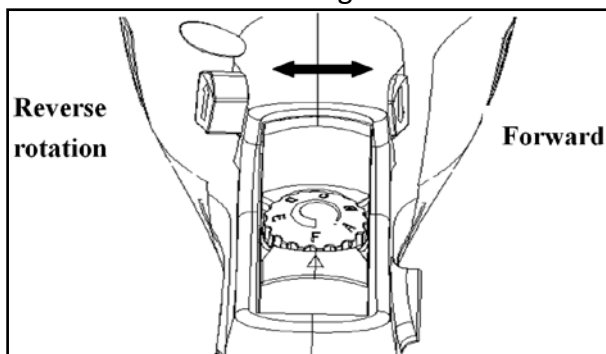

## Switching on and off

- To switch the tool on, press the variable speed switch (1). The tool speed depends on how far you press the switch.

- Set the variable speed control knob (4) to the required speed range.

- As a general rule, use low speeds for large diameter drill bits and high speeds for smaller diameter drill bits.

- For continuous operation, press the lock-on button (2) and release the variable speed switch.

This option is available only in forward (clockwise) rotation.

- To switch the tool off, release the variable speed switch.

To switch the tool off when in continuous operation, press the variable speed switch once more and release it.

## Setting the drilling depth

- Slacken the side handle (7) by turning the grip counter clockwise.

- Set the depth stop (8) to the desired position. The maximum drilling depth is equal to the distance between the top of the bit and the front end of the depth stop.

- Tighten the side handle by turning the grip clockwise.

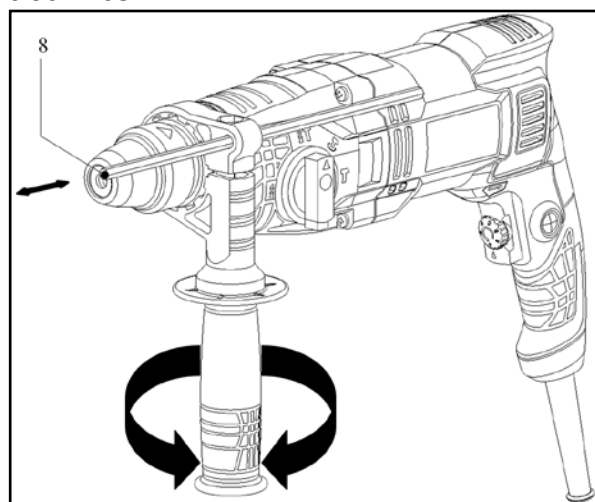

## Accessories

The performance of your tool depends on the accessory used. The accessories are engineered to high quality standards and designed to enhance the performance of your tool. By using these accessories you will get the very best from your tool.

## MAINTENANCE AND CLEANING

### **Maintenance**

Your corded/cordless appliance /tool has been designed to operate over a long period of time with a minimum of maintenance. Continuous satisfactory operation depends upon proper tool care and regular cleaning.

**Warning!** Before performing any maintenance on corded/cordless power tools:

- Switch off and unplug the appliance/tool.
- Or switch off and remove the battery from the appliance/tool if the appliance/tool has a separate battery pack.
- Or run the battery down completely if it is integral and then switch off.
- Unplug the charger before cleaning it. Your charger does not require any maintenance apart from regular cleaning.
- Regularly clean the ventilation slots in your appliance/tool/charger using a soft brush or dry cloth.
- Regularly clean the motor housing using a damp cloth. Do not use any abrasive or solvent-based cleaner.
- Regularly open the chuck and tap in to remove any dust from the interior (when fitted).

# LUMBERJACK GUARANTEE

## 1. Guarantee

**1.1** Lumberjack guarantees that for a period of 12 months from the date of purchase the components of qualifying products (see clauses 1.2.1 to 1.2.8) will be free from defects caused by faulty construction or manufacture.

**1.2.** During this period Lumberjack, will repair or replace free of charge any parts which are proved to be faulty in accordance with paragraph 1.1 providing that:

**1.2.1** You follow the claims procedure set out in clause 2

**1.2.2** Lumberjack and its authorised dealers are given reasonable opportunity after receiving notice of the claim to examine the product

**1.2.3** If asked to do so by Lumberjack or its Authorised dealer, you return the product at your own cost to Lumberjack's or supplying Authorised Dealer's premises, for the examination to take place clearly stating the Returns Material Authorisation number given by Lumberjack or an Authorised Dealer.

**1.2.4** The fault in question is not caused by industrial use, accidental damage, fair wear and tear, wilful damage, neglect, incorrect electrical connection, misuse, or alteration or repair of the product without approval.

**1.2.5** The product has been used in a domestic environment only

**1.2.6** The fault does not relate to consumable items such as blades, bearings, drive belts, or other wearing parts which can reasonably be expected to wear at different rates depending on usage.

**1.2.7** The product has not been used for hire purposes.

**1.2.8** The product has been purchased by you as the guarantee is not transferable from a private sale.

## 2. Claims Procedure

**2.1** In the first instance please contact the Authorised Dealer who supplied the product to you. In our experience many initial problems with machines that are thought to be faulty due to faulty parts are actually solved by correct setting up or adjustment of the machine. A good Authorised Dealer should be able to resolve the majority of these issues much more quickly than processing a claim under the guarantee. If a return is requested by the Authorised Dealer or Lumberjack, you will be provided with a Returns Material Authorisation number which must be clearly stated on the returned package, and any accompanying correspondence. Failure to provide a Returns Material Authorisation number may result in item being refused delivery at an Authorised Dealer.

**2.2** Any issues with the product resulting in a potential claim under the guarantee must be reported to the Authorised Dealer from which it was purchased within 48 hours of Receipt.

**2.3** If the Authorised Dealer who supplied the product to you has been unable to satisfy your query, any claims made under this Guarantee should be made directly to Lumberjack. The Claim itself should be made in a letter setting out the date and place of purchase, giving a brief explanation of the problem which has led to the claim. This letter should be then sent with proof

# LUMBERJACK GUARANTEE

of purchase to Lumberjack. If you include a contact number with this it will speed your claim up.

**2.4** Please note that it is essential that the letter of claim reaches Lumberjack on the last day of this Guarantee at the latest. Late claims will not be considered.

## **3. Limitation of Liability**

**3.1** We only supply products for domestic and private use. You agree not to use the product for any commercial, business or resale purposes and we have no liability to you for any loss of profit, loss of business, business interruption or loss of business opportunity.

**3.2** This Guarantee does not confer any rights other than these expressly set out above and does not cover any claims for consequential loss or damage. This Guarantee is offered as an extra benefit and does not affect your statutory rights as a consumer.

## **4. Notice**

This Guarantee applies to all product purchased from an Authorised Dealer of Lumberjack within the United Kingdom. Terms of Guarantee may vary in other countries.

## CE DECLARATION OF CONFORMITY

**TOOLSAVE**

Unit C, Manders Ind. Est.,  
Old Heath Road, Wolverhampton,  
WV1 2RP.

Tel: 01902 450 470

**Declares that the Rotary Hammer(RHD1150)**  
Is in compliance with the regulations included in the Directives:2006/42/EC

## EC DECLARATION OF CONFORMITY

Certificate for EC-type examination delivered by Intertek Testing Services Shanghai, Building No. 86,  
1198 Qinzhou Road(North), Shanghai 200233,China. (Verification No.:190801841SHA-V1)

Person who declares: Bill Evans

---

**UK  
CA**

20.09.2025

The Director



## Parts List

NO.	NAME	NO.	NAME
1	rubber	45	swing bearing set
2	Ring $\varnothing$ 14x1.5	46	needle bearing KV151814
3	washer $\varnothing$ 16x $\varnothing$ 22x1.5	47	gear shaft 33 teeth
4	ring $\varnothing$ 19x1.8	48	clutch spring
5	ball holder	49	spring fix plastic parts
6	Ring $\varnothing$ 21.2x $\varnothing$ 32.5x5.5	50	washer
7	Ball $\Phi$ 7.14	51	steel sleeve $\varnothing$ 30x $\varnothing$ 35x9
8	Ring	52	O-ring $\varnothing$ 52.7x7.4
9	spring W21-29.5x1.5x21	53	scew M5x16
10	teleflex&cylinder	54	Swing bearing board
11	oil seal	55	aluminum holder
12	limit sleeve of hammer lever	56	wool felt
13	screw ST4.2x20	57	bearing 609RS
14	plastic housing	58	bearing board
15	oil seal	59	screw M4*10
16	needle bearing sleeve	60	Rotor
17	impact hammer	61	dustproof washer
18	Ring $\varnothing$ 28x1.6	62	bearing 627RS
19	Ring $\varnothing$ 30x $\varnothing$ 42x2	63	Fan Guide
20	button	64	screw ST3.9x60
21	spring $\varnothing$ 4.5x $\varnothing$ 0.6x35	65	stator
22	knob	66	screw ST2.9x10
23	O-ring $\varnothing$ 16x2	67	carton brush
24	big spring $\varnothing$ 32x $\varnothing$ 4.5x38.5	68	brush holder
25	big gear 40teeth	69	motor housing
26	round pin $\Phi$ 2.5x10	70	left handle
27	safety clutch	71	cable board
28	ring $\varnothing$ 27x1.6	72	screw ST3.9x14
29	hammer rod set	73	Electric capacity
30	o-ring $\varnothing$ 16.2x4.5	74	switch
31	o-ring $\varnothing$ 9.2x3.5	75	right and left rod
32	low sheath	76	inductance
33	impact bolt	77	screw ST3.9x30
34	o-ring $\varnothing$ 15x3	78	screw ST3.9x20
35	piston $\varnothing$ 25x69	79	right handle
36	piston pin	80	cable cover
37	ring	81	cable
38	needle bearing HK0709	82	hoop
39	Fix plate	83	T-screw
40	screw ST3.9x10	84	bracker
41	Cone Gear	85	Auxiliary handle
42	clution plastic parts	86	button
43	bearing $\varnothing$ 9x $\varnothing$ 20x5	87	spring $\Phi$ 7.2x $\Phi$ 0.9x15
44	needle bearing HK091308	88	Depth ruler

# Parts Diagram

