



SAFETY AND OPERATING MANUAL
Inverter Generator
IG950i/IG1200i/IG2000i



ORIGINAL INSTRUCTIONS



IG950i/IG1200i/IG2000i

TABLE OF CONTENTS

Welcome to Autojack!

Dear Customer, Congratulations on your purchase. Before using the Product for the first time please be sure to read these instructions for use.

They provide you with all information necessary for using the product safely and to ensure its long service life.

Closely observe all safety information in these instructions!

| | |
|--------------------------------------------------|-----------|
| General Power Tool Safety Warnings..... | 01 |
| Symbols & Cable Rating Chart | 04 |
| Machine Details and Product features..... | 05 |
| Assembly..... | 11 |
| Operation..... | 13 |
| Maintenance and Service..... | 17 |
| Troubleshooting..... | 19 |
| Autojack Guarantee..... | 20 |
| Declaration of Conformity..... | 22 |
| Parts list/Parts Diagram..... | 23 |

GENERAL POWER TOOL SAFETY WARNINGS

WARNING Read all safety warnings and all instructions. Failure to follow the warnings and instructions may result in electric shock, fire and/or serious injury.

Save all warnings and instructions for future reference. The term "power tool" in the warnings refers to your electric (corded) power tool or battery-operated (cordless) power tool.

1. Work area safety

a) Keep work area clean and well lit. Cluttered or dark areas invite accidents.

b) Do not operate power tools in explosive atmospheres, such as in the presence of flammable liquids, gases or dust. Power tools create sparks which may ignite the dust or fumes.

c) Keep children and bystanders away while operating a power tool. Distractions can cause you to lose control.

2. Electrical safety

a) Power tool plugs must match the outlet. Never modify the plug in any way. Do not use any adapter plugs with grounded power tools. Unmodified plugs and matching outlets will reduce risk of electric shock.

b) Avoid body contact with grounded surfaces, such as pipes, radiators, ranges and refrigerators. There is an increased risk of electric shock if your body is grounded.

c) Do not expose power tools to rain or wet conditions. Water entering a power tool will increase the risk of electric shock.

d) Do not abuse the cord. Never use the cord for carrying, pulling or unplugging the power tool. Keep cord away from heat, oil, sharp edges or moving parts. Damaged or entangled cords increase the risk of electric shock.

e) When operating a power tool outdoors, use an extension cord suitable for outdoor use. Use of a cord suitable for outdoor use reduces the risk of electric shock.

f) If operating a power tool in a damp location is unavoidable, use a residual current device (RCD) protected supply. Use of an RCD reduces the risk of electric shock.

3. Personal safety

a) Stay alert, watch what you are doing and use common sense when operating a power tool. Do not use a power tool while you are tired or under the influence of drugs, alcohol or medication. A moment of inattention while operating power tools may result in serious personal injury.

b) Use personal protective equipment. Always wear eye protection. Protective equipment such as dust mask, non-skid safety shoes, hard hat, or hearing protection used for appropriate conditions will reduce personal injuries.

c) Prevent unintentional starting. Ensure the switch is in the off position before connecting to power source and/or battery pack, picking up or carrying the tool. Carrying power tools with your finger on the switch or energising power tools that have the switch on invites accidents.

d) Remove any adjusting key or wrench before turning the power tool on. A wrench or a key left attached to a rotating part of the power tool may result in personal injury.

GENERAL POWER TOOL SAFETY WARNINGS

e) Do not overreach. Keep proper footing and balance at all times. This enables better control of the power tool in unexpected situations.

f) Dress properly. Do not wear loose clothing or jewellery. Keep your hair, clothing and gloves away from moving parts. Loose clothes, jewellery or long hair can be caught in moving parts.

g) If devices are provided for the connection of dust extraction and collection facilities, ensure these are connected and properly used. Use of dust collection can reduce dust-related hazards.

4. Power tool use and care

a) Do not force the power tool. Use the correct power tool for your application. The correct power tool will do the job better and safer at the rate for which it was designed.

b) Do not use the power tool if the switch does not turn it on and off. Any power tool that cannot be controlled with the switch is dangerous and must be repaired.

c) Disconnect the plug from the power source and/or the battery pack from the power tool before making any adjustments, changing accessories, or storing power tools. Such preventive safety measures reduce the risk of starting the power tool accidentally.

d) Store idle power tools out of the reach of children and do not allow persons unfamiliar with the power tool or these instructions to operate the power tool. Power tools are dangerous in the hands of untrained users.

e) Maintain power tools. Check for misalignment or binding of moving parts, breakage of parts and any other condition that may affect the power tool's operation. If damaged, have the power tool repaired before use. Many accidents are caused by poorly maintained power tools.

5. Service

a) Have your power tool serviced by a qualified repair person using only identical replacement parts. This will ensure that the safety of the power tool is maintained.

b) If the replacement of the supply cord is necessary, this has to be done by the manufacturer or its agent in order to avoid a safety hazard.

GENERAL POWER TOOL SAFETY WARNINGS

6. Additional Safety Instructions for Generators

- a). Keep the generator at least 1 m (3 ft.) from buildings or other equipment, or the engine may overheat.
- b). Place the generator on a solid, flat surface.
- c). Make sure the surrounding area is free from any material that could burn or be damaged by heat.
- d). Never move or tilt the generator whilst it is switched on.
- e). Always switch the engine OFF when refuelling.
- f). Always refuel in a well ventilated area.
- g). Never overfill the tank, fill to the level specified .
- h). Never smoke whilst refuelling and avoid smoking or using a naked flame near the generator.
- i). Never start the engine if there is spilt fuel. Any spillage must be wiped clean and the generator allowed to dry before attempting to start the engine.
- j). Never use the generator in wet conditions unless it is well protected/covered. Under these conditions, adequate ventilation MUST be provided.
- k). Never operate the generator with wet hands
- l). Never use water or any other liquids to clean the generator.
- m). Make sure you ground (earth) the generator.

- n). Always make sure the applied load does not exceed the generator rating. Overloading the generator is dangerous and could cause serious damage.
- o). Always disconnect the generator when carrying out any maintenance.
- p). Always allow the generator to reach operating speed before connecting a load.
- q). Never allow the generator to run out of fuel when a load is connected.
- r). Never transport the generator with fuel in the tank.
- s). Never connect the generator to a commercial or residential power supply; e.g. ring main.
- t). Never allow the generator air vents to become blocked.

SYMBOLS AND POWER RATING CHART



Danger! – Read the operating instructions to reduce the risk of injury.



Caution! Wear safety goggles.



Caution! Wear ear defenders. The impact of noise can cause damage to hearing.

MACHINE DETAILS AND PRODUCT FEATURES

Machine Details

Specifications:

IG950i

Engine

Engine model – XY139F-6

Type – petrol

Displacement – 40m³

Ignition type – C.D.I

Fuel tank capacity – 2.1L

Maximum run time at 3/4 load – 5.3h

Engine oil capacity – 0.25L

Generator

Rated Frequency – 50Hz

Rated AC voltage – 230V

Max output power – 800W

Continuous output power – 700W

Output type – modified sine wave

Rated DC voltage – 12V

Rated DC current – 4A

Rated output current – 3.04A

Rated power factor – 1

Performance Class – G1

Quality Class – A

Noise Level(LWA) - 58dB(A)
(taken at 7 m)

IP Rating – IP23M

Package Contents:

Inverter Generator

12Volt Connecting Lead Assembly

Spark Plug Box Spanner

Cross-Head Screwdriver

Intended Use

Designed to generate electric energy

Using equipment in ways other than its intended use the user and not the manufacture will be liable for any damage or injuries caused.

Also note that this equipment is not designed for commercial or industrial use. Warranty will be voided if used for these purposes.

1. Air vent knob
2. Fuel cap
3. Fuel valve knob
4. Starting handle
5. Side maintenance cover
6. Top maintenance cover
7. Muffler
8. Choke
9. Engine ON/OFF switch
10. Earthing point
11. Economy control switch
12. AC socket
13. DC socket
14. DC circuit breaker
15. Output indicator
16. Overload indicator
17. Oil alarm indicator
18. Primer bulb

MACHINE DETAILS AND PRODUCT FEATURES

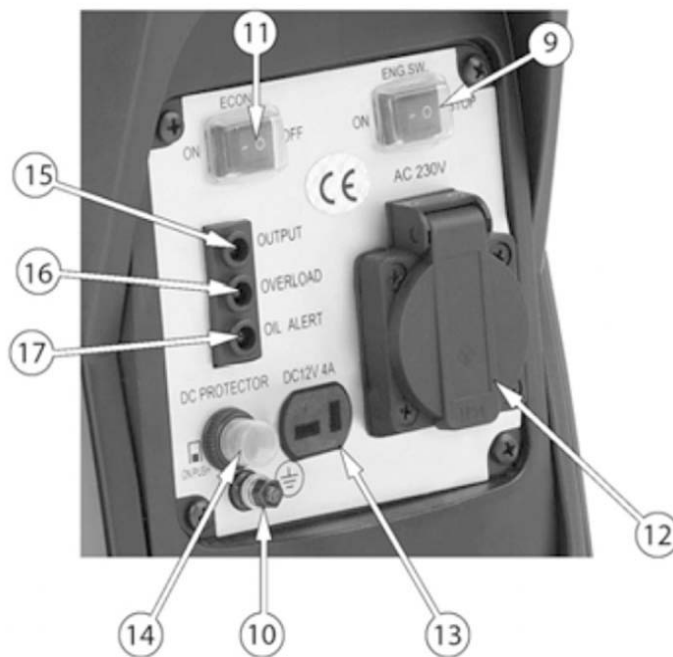

MACHINE DETAILS AND PRODUCT FEATURES

Machine Details

Specifications:

IG1200i

Engine

Engine model – XY144F-1

Type – petrol

Displacement – 60m³

Ignition type – C.D.I

Fuel tank capacity – 3L

Maximum run time at 3/4 load – 5.5h

Engine oil capacity – 0.27L

Generator

Rated Frequency – 50Hz

Rated AC voltage – 230V

Max output power – 1100W

Continuous output power – 1000W

Output type – modified sine wave

Rated DC voltage – 12V

Rated DC current – 4A

Rated output current – 4.354A

Rated power factor – 1

Performance Class – G1

Quality Class – A

Noise Level(LWA) - 58dB(A)
(taken at 7 m)

IP Rating – IP23M

Package Contents:

Inverter Generator

12Volt Connecting Lead Assembly

Spark Plug Box Spanner

Cross-Head Screwdriver

Intended Use

Designed to generate electric energy

Using equipment in ways other than its intended use the user and not the manufacture will be liable for any damage or injuries caused.

Also note that this equipment is not designed for commercial or industrial use. Warranty will be voided if used for these purposes.

1. Air vent knob
2. Fuel cap
3. Fuel valve knob
4. Starting handle
5. Side maintenance cover
6. Top maintenance cover
7. Muffler
8. Choke
9. Engine ON/OFF switch
10. Earthing point
11. Economy control switch
12. AC socket
13. DC socket
14. DC circuit breaker
15. Output indicator
16. Overload indicator
17. Oil alarm indicator
18. Primer bulb

MACHINE DETAILS AND PRODUCT FEATURES

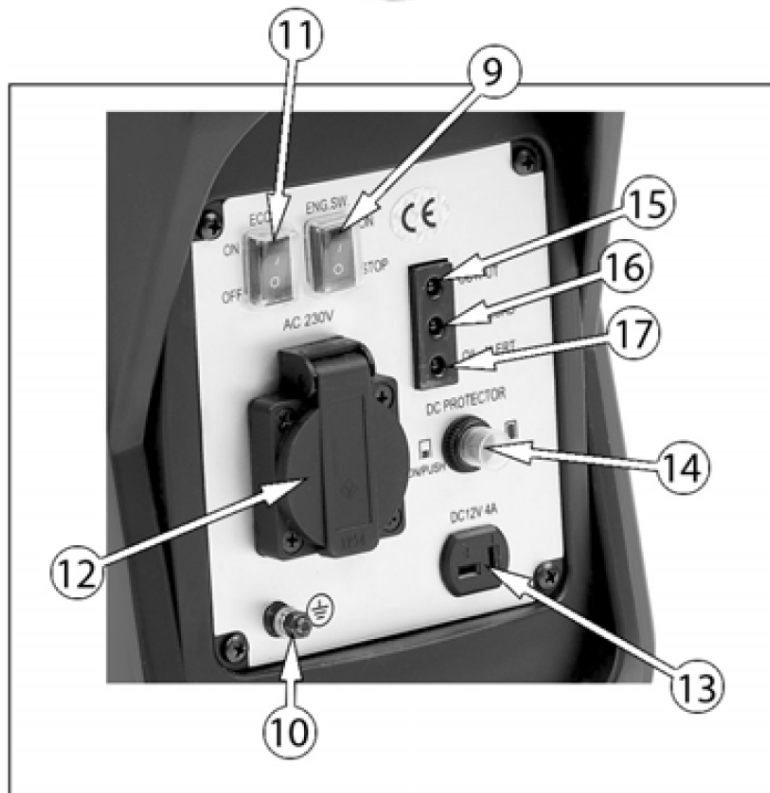

MACHINE DETAILS AND PRODUCT FEATURES

Machine Details

Specifications:

IG2000i

Engine

Engine model – XY152F-4

Type – petrol

Displacement – 99m³

Ignition type – C.D.I

Fuel tank capacity – 4.1L

Maximum run time at 3/4 load – 4.5h

Engine oil capacity – 0.52L

Generator

Rated Frequency – 50Hz

Rated AC voltage – 230V

Max output power – 2000W

Continuous output power – 1700W

Output type – modified sine wave

Rated DC voltage – 12V

Rated DC current – 4A

Rated output current – 7.39A

Rated power factor – 1

Performance Class – G1

Quality Class – A

Noise Level(LWA) - 58dB(A)
(taken at 7 m)

IP Rating – IP23M

Package Contents:

Inverter Generator

12Volt Connecting Lead Assembly

Spark Plug Box Spanner

Cross-Head Screwdriver

Intended Use

Designed to generate electric energy

Using equipment in ways other than its intended use the user and not the manufacture will be liable for any damage or injuries caused.

Also note that this equipment is not designed for commercial or industrial use. Warranty will be voided if used for these purposes.

1. Air vent knob
2. Fuel cap
3. Fuel valve knob
4. Starting handle
5. Side maintenance cover
6. Top maintenance cover
7. Muffler
8. Choke
9. Engine ON/OFF switch
10. Earthing point
11. Economy control switch
12. AC socket
13. DC socket
14. DC circuit breaker
15. Output indicator
16. Overload indicator
17. Oil alarm indicator
18. Primer bulb

MACHINE DETAILS AND PRODUCT FEATURES

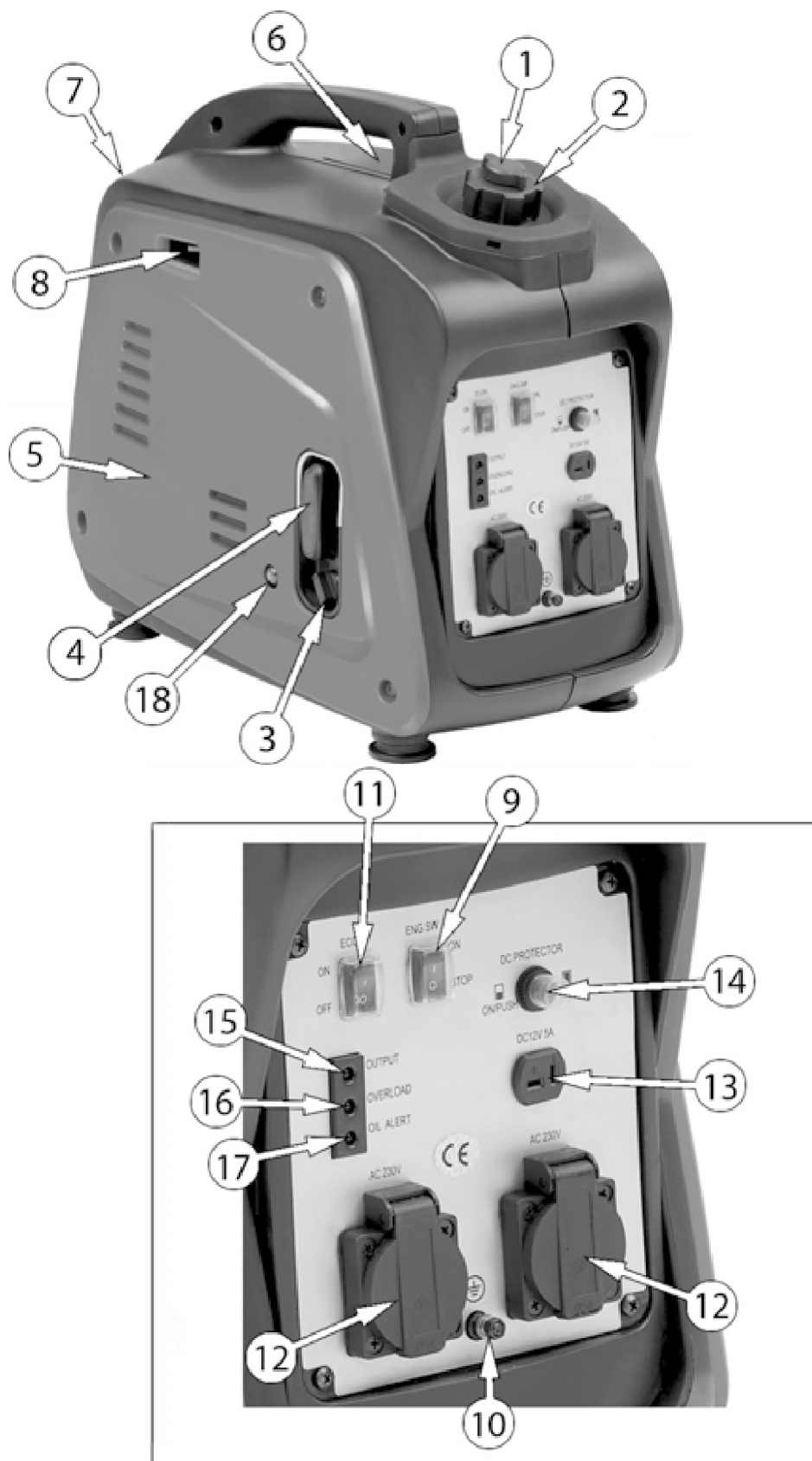

Assembly

Before using the generator

IMPORTANT: Generators should ALWAYS be earthed. Make sure you earth the generator.

Before using your generator check that:

- The generator is in good condition and free from any damage.
- The generator is clean and free from fuel or oil spillage.
- The generator is correctly located for use
- There is no leakage.

Note: To avoid accidental spillage of fuel, always use a funnel to fill the fuel tank. If fuel is spilt it must be removed from the unit before attempting to start the engine.

Earthing

WARNING: It is advisable to properly earth your generator before starting using a wire and a small metal earth spike. The wire and earth are not supplied with the unit.

An earth spike and cable can be purchased at your local camping supplier, or alternatively an earth spike can be made, and it is suggested you get advice from a qualified electrician.

To make a spike use a copper tube or copper rod 12mm diameter, a minimum length of 200mm and with an M6 machine screw one end.

The cable used should be a maximum length of 1 metre and a minimum of 1.0mm² to carry a 10 amp load.

Attach the cable to the generator at the earth point screw on the generator.

When pushing the spike into the ground the generator must not be running and it is suggested that the spike is pushed into the ground by at least 100mm.

Earthing of generators is covered in BS7430:2011, If you have any doubts about this subject consult a qualified electrician.

Checking the air filter

1. Remove the side maintenance panel.



2. Remove the air filter cover screw shown on the right.
3. Slide out the air filter panel.

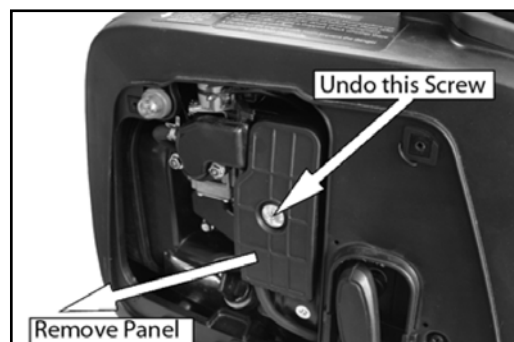

4. Remove the air filter element.

Assembly

5. If the air filter is damaged contact the Autojack spare parts department for a replacement.
- If the filter is dirty, wash it in a solution of warm water and mild detergent and rinse thoroughly. Leave the filter to dry completely. Once it is dry immerse the filter in clean engine oil and squeeze the filter to remove excess oil.

WARNING: Do not use flammable solvents or petrol to clean the air filter.

6. Replace the filter into its original position and secure the air filter cover. Reattach the side maintenance panel.

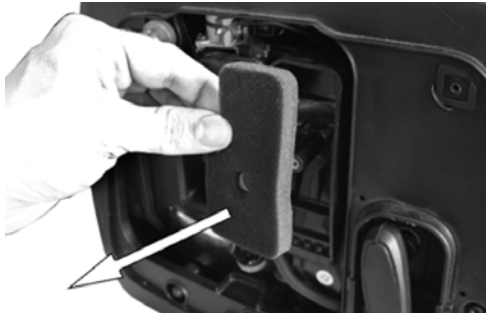

Checking the Engine oil level

WARNING: Your generator may not be supplied with oil, always ensure that there is sufficient oil before use.

WARNING: To carry out this check, the engine must be off.

1. Remove the side maintenance panel.



2. Turn the oil filler cap anti-clockwise and remove from the oil reservoir, wipe the dipstick with a clean cloth.

3. Insert the dipstick back into the oil filler tube and then remove it again.



4. If the oil is below the Min. level on the dipstick, top up the oil reservoir with fresh oil.

- Do not fill above the max level mark (0.3 litres)

- We recommend the use of SAE30 oil in this generator.

5. Replace the oil filler cap.

6. Replace the left side maintenance panel.

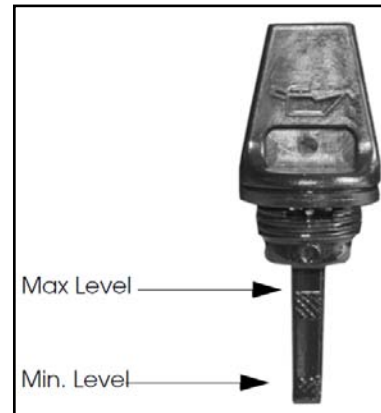

Checking the fuel level

WARNING: Make sure there is fuel in the tank when using the generator. Running out of fuel or stopping the engine suddenly with a load connected could cause serious damage.

1. To check the fuel level, open the fuel filler cap.

2. Slowly add fuel to the fuel tank (maximum 2.1 litres)

- Do not overfill the fuel tank.

Assembly / Operation

3. Replace the fuel filler cap securely.

WARNING: Fuel is highly flammable and poisonous.

WARNING: SEE "GENERAL SAFETY RULES" and read them carefully before refueling.

WARNING: Do not fill above the top of the fuel filter or it may overflow when the fuel heats up and expands.

WARNING: Wipe up any spilt fuel immediately.

WARNING: After refueling, make sure the fuel filler cap is tightened securely.



Recommended fuel

Your generator has been designed to use regular unleaded petrol with a octane number of 86 or higher.

Starting the engine

1. Remove all connections from the AC sockets.

2. Hold the fuel tank cap so that it will not move, and turn the air vent knob to the 'open' position.

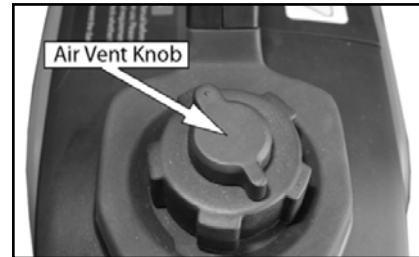

3. Turn fuel valve to the ON position (Pointing right).



4. Set the engine switch to 'ON'.

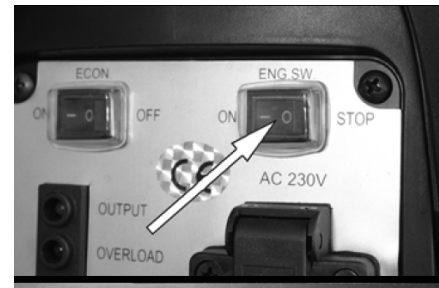

5. Move the choke lever to the right, to the 'choke' position.



Operation

6. If this is the first time you are using the generator or if the generator had run out of fuel the last time you used it, pump the primer bulb a minimum of 6 times to introduce fuel into the carburetor.



7. Hold the generator handle firmly and pull the starting handle lightly until you start to feel resistance and then pull up sharply to start the engine.



NOTE: you may have to do this more than once.
WARNING: Once the generator has started, release the handle slowly to avoid injury/damage as it whips back.
NOTE: When you first start the generator, the overload indicator may light up for a few seconds, this is normal. If the overload indicator is still lit after 5 seconds, stop the engine and contact your AUTOJACK dealer.

8. Once the engine has warmed up, move the choke lever to the left, to the "run" position.



Economy switch:

ON: Recommended to minimise fuel consumption and further reduce noise levels when no load is applied to the generator. Engine speed varies with the load.

OFF: The smart throttle system does not operate.

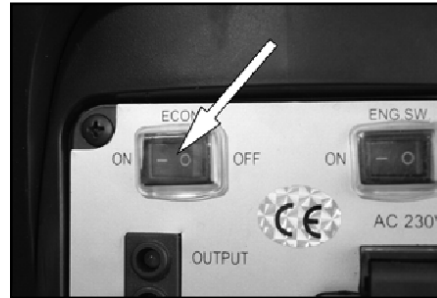

CAUTION: The economy control does not work effectively if the electrical appliance requires 'BURSTS' of power.

CAUTION: Turn the economy control feature off when connecting high load appliances or when connecting to the DC output.

Connecting electrical devices

The generator can supply both 230V AC and 12V DC

AC power

1. Start the engine.
2. Make sure the appliance is turned off before connecting it to the generator.
3. Connect the appliance (max load) to the generator.



Operation

Caution: Make sure that the appliance being connected is in good working order if it begins to act abnormally or stops suddenly. Disconnect it from the generator.

Caution: Make sure the appliance does not exceed the maximum rated load for the generator.

Caution: Any device which contains an inductive load e.g. devices that contain a motor may require more current on startup.

DC power

1. Set the economy control switch to 'OFF'.
2. Start the generator.
3. Make sure the appliance is turned off before connecting it to the generator.
4. Connect the 12V appliance (max 4A) to the generator.

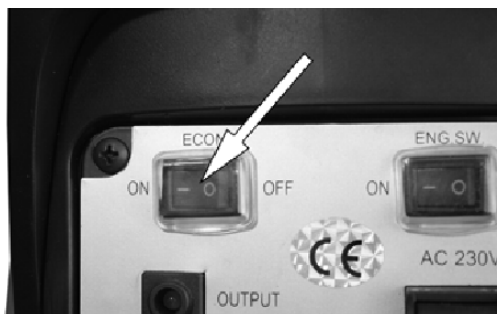

DC power (Topping up car batteries)

WARNING: For your safety perform the following instructions in the order shown.

WARNING: You should only use this generator to 'Top up' the battery, also trying to charge a completely flat battery may cause the fuse to blow.

1. Set the economy control switch to 'OFF'.

2. Start the generator.

3. Connect the battery charging leads to the battery.

-Make sure you clamp the red wire to the positive(+) terminal and the black wire to the negative (-) terminal of the battery

4. Connect the battery charging leads to the generator.

-The battery will begin to charge.

5. Monitor the voltage across the battery regularly during charging and disconnect the battery when the voltage reaches 14.4 volts.



CAUTION: When disconnecting the battery, always disconnect the negative lead first.

DC over load protector

If the DC overload protector activates, wait for a few minutes and then press the reset button shown on the right.



Operation

Indicator lights

Output

The output indicator(Green) will remain on during normal operation.

Overload

The overload indicator(Red) will light up if there is an overload or a short circuit in the connected appliance.

If this happens, proceed as follows:

1. Turn off any connected electrical devices and stop the engine.
2. Reduce the total wattage of connected electric devices to within the rated output of the generator.
3. Check air inlet and around the control unit. If any blockages are found, remove them.
4. After checking, restart the engine.

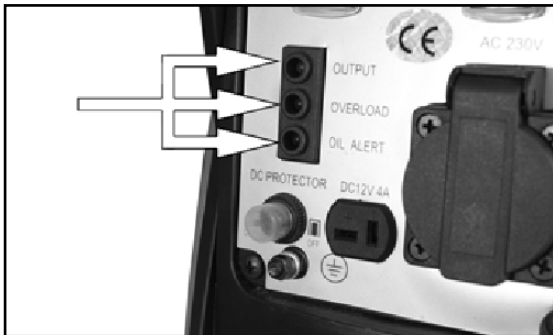

Oil alert

The oil alert indicator(Red) will light up when the oil level is low.

-To add oil

Shutting down the generator

To stop the generator in an emergency simply set the engine switch to 'OFF'

NOTE: Turn off any electric devices.

NOTE: Set the economy control switch to the 'O'(OFF) position.

1. Disconnect any electric devices.
2. Turn the fuel valve knob to 'OFF'(pointing left).



3. Turn the air vent knob to the 'Close' position.

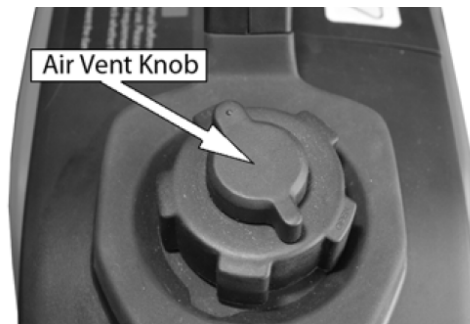

4. Set the engine switch to the "O"(OFF) position.



MAINTENANCE AND SERVICE

Engine oil(every 20 hours of use)

CAUTION: Prolonged exposure to used engine oil dangerous, always wash your hands thoroughly after handling used engine oil.

1.Remove the maintenance panel shown on the right.



2.Turn the oil filler cap anti-clockwise and remove from the oil tank.



3.Tilt the generator to allow the oil to drain out of the oil reservoir into a suitable container.

NOTE: You may need assistance with this step as the generator is heavy.

4.Fill the oil reservoir with fresh oil.

- Do not fill above the max level mark(0.3 litres).

- We recommend the use of SAE30 oil in this generator.

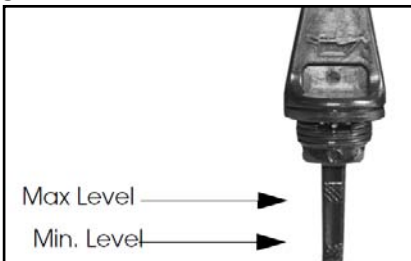

5.Replace the oil filler cap and maintenance panel.

Environmental protection

One of the most damaging sources of pollution is oil. Do not throw away used engine oil in with your domestic waste or down drains and sinks. Place it in a leak proof container and dispose of it according to local regulations.

Air filter(every 50 hours of use)

1.Remove the maintenance panel shown on the right..



2.Remove the air filter cover screw.

3.Remove the air filter panel.

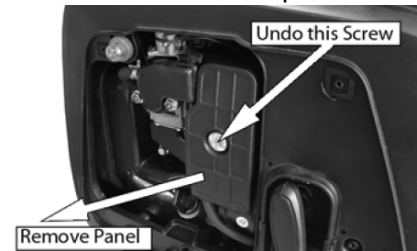

4.Remove the air filter element.

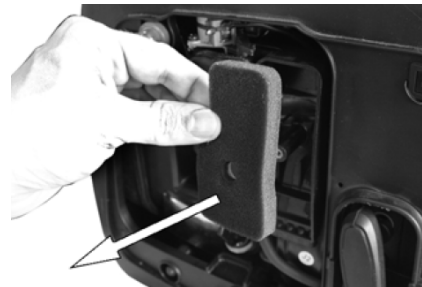

5.If the air filter is damaged contact the AUTOJACK spare parts department for a replacement.

WARNING: Do not use flammable solvents or petrol to clean the air filter.

6.Replace the filter into its original position and replace and secure the air filter cover.

MAINTENANCE AND SERVICE

Spark plug (every 50 hours of use)

CAUTION: Allow the engine to cool before removing the spark plug.

1. Remove the top maintenance panel.

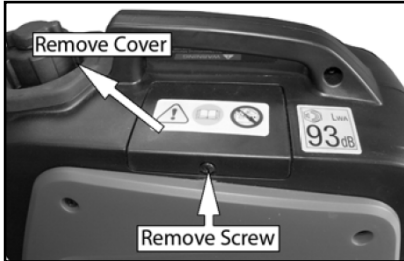

2. Remove the spark plug cap from the spark plug.

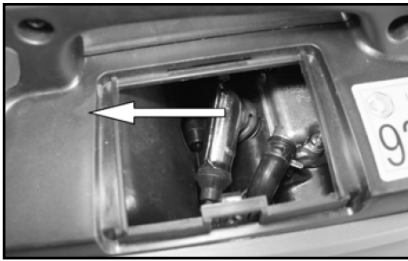

3. Fit the spark plug box spanner over the spark plug as shown.

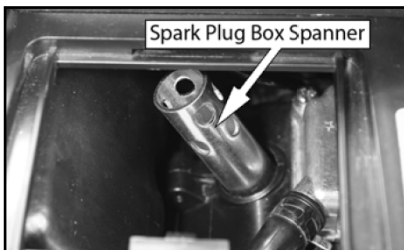

4. Remove the side panel and use the screwdriver supplied to turn the spark plug box spanner as shown.



5. When the spark plug has been removed, check for discoloration and use a wire brush to remove any carbon build up.

6. Check the spark plug gap (a) with a feeler gauge, it should be between 0.6 and 0.7 mm.

-Adjust if necessary.

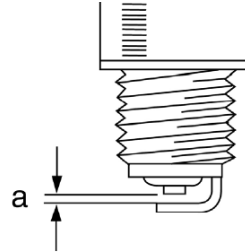

7. Check the overall condition of the spark plug and replace if damaged.

8. Reinstall the spark plug and replace the spark plug cap and top panel.

Fuel tank filter (every 100 hours of use or every 6 months)

Just inside the fuel tank is a fuel filter, check this filter periodically and remove any contaminants which may have accumulated.

1. Remove the fuel tank cap
2. Lift out the filter inside.
3. Clean the filter with solvent.
4. Replace the filter and fuel tank cap.



Troubleshooting

| Problem | Cause | Solution |
|---------------------------------------------|----------------------------------------------------------|----------------------------------------------------------------------------------------------|
| The generator fails to start | Engine switch is off | Set the engine switch to 'on' |
| | Not enough oil in the generator | Add more oil |
| | No fuel | Add more fuel |
| | Spark plug not working correctly | Change the spark plug correctly |
| The generator fails to generate electricity | The device you are trying to power is faulty | Make sure the device you want to power is working properly |
| | The overload indicator is on | Remove the appliance immediately, do not connect any appliance that requires more than 800W. |
| | (DC supply only) The DC overload protector has activated | Press the reset button |
| The generator is difficult to start | The air filter is dirty | Clean the air filter |

If this does not solve your problem, please contact the AUTOJACK service department.

AUTOJACK GUARANTEE

1. Guarantee

1.1 Autojack guarantees that for a period of 12 months from the date of purchase the components of qualifying products (see clauses 1.2.1 to 1.2.8) will be free from defects caused by faulty construction or manufacture

1.2 During this period, Autojack, will repair or replace free of charge any parts which are proved to be faulty in accordance with paragraph 1.1 providing that:

1.2.1 You follow the claims procedure set out in clause 2.

1.2.2 Autojack and its Authorised Dealers are given reasonable opportunity after receiving notice of the claim to examine the product.

1.2.3 If asked to do so by Autojack or its Authorised Dealer, you return the product at your own cost to Autojack's or the supplying Authorised Dealer's Premises, For the examination to take place clearly stating the Returns Material Authorisation Number given by Autojack or an Authorised Dealer.

1.2.4 The fault in question is not caused by industrial use, accidental damage, fair wear and tear, wilful damage, neglect, incorrect electrical connection, misuse, alteration or repair of the product without approval.

1.2.5 The product has been used in a domestic environment only.

1.2.6 The fault does not relate to consumable items such as blades, bearings, drive belts or other wearing parts which can reasonably be expected to wear at different rates depending on usage.

1.2.7 The product has not been used for hire purposes.

1.2.8 The product has been purchased by you, as the guarantee is not transferable from a private sale.

2. Claims Procedure

2.1 In the first instance please contact the Authorised Dealer who supplied the product to you. In our experience many initial problems with machines that are thought to be fault due to faulty parts are actually solved by correct setting up or adjustment of the machine. A good Authorised Dealer should be able to resolve the majority of these issues much more quickly than processing a claim under the guarantee. If a return is requested by the Authorised Dealer or Autojack, you will be provided with a Returns Material Authorisation Number which must be clearly stated on the returned package, and any accompanying correspondence. Failure to provide a Returns Material Authorisation Number may result in item being refused delivery.

AUTOJACK GUARANTEE

2.2 Any issues with the product resulting in a potential claim under the guarantee must be reported to the Authorised Dealer from which it was purchased within 48 hours of receipt.

2.3 If the authorised Dealer who supplied the product to you has been unable to satisfy your query, any claims made under this guarantee should be made directly to Autojack. The claim itself should be made in a letter setting out the date and place of purchase, giving a brief explanation of the problem which has led to the claim. This letter should be then sent with proof of purchase to Autojack. If you include a contact number with this it will speed your claim up.

2.4 Please note that it is essential that the letter of claim reaches Autojack on the last day of this guarantee at the latest. Late claims will not be considered.

3. Limitation of Liability.

3.1 We only supply products for domestic and private use. You agree not to use the product for any commercial, business or resale purposes and we have no liability to you for any loss of profit, loss of business, business interruption or loss of business opportunity.

3.2 This guarantee does not confer any rights other than these expressly set out above and does not cover any claims for consequential loss or damage. This guarantee is offered as an extra benefit and does not affect your statutory rights as a consumer.

4. Notice

This guarantee applies to all product purchased from an Authorised Dealer of Autojack within the United Kingdom. Terms of guarantee may vary in other countries.

CE DECLARATION OF CONFORMITY

TOOLSAVE

Unit C, Manders Ind. Est.,
Old Heath Road, Wolverhampton,
WV1 2RP.

Tel: 01902 450 470

Declares that the Inverter Generator (IG950i)
Is in compliance with the regulations included in the Directives:2014/30/EU

EC DECLARATION OF CONFORMITY

Certificate for EC-type examination delivered by Interk Testing Services Hangzhou 16
No. 1 Ave., Xiasha Economic Development District, Hangzhou 310018, China
(Verification No.:160400544HZH-V1)

Person who declares: Bill Evans



17/05/21

The Director

A handwritten signature in black ink, appearing to be 'Bill Evans', written over a light grey rectangular background.

Parts List / Parts Diagram(IG950i)

FIG.A CRANKCASE ASSY

| No. | Description | No. | Description |
|-----|--------------------------|-----|---------------------------|
| 1 | Screw M5×20 | 14 | Dowel Pin 4×8 |
| 2 | Cylinder Head Cover | 15 | Ventilation Nozzle |
| 3 | Cylinder Head Cover Seal | 16 | Lower Crankcase |
| 4 | Valve Oil Seal | 17 | Screw M5×16 |
| 5 | Dual-Head Bolts M5×70 | 18 | Screw M5×40 |
| 6 | Dual-Head Bolts M5×28 | 19 | Rubber One-Way Valve |
| 7 | Cam Chamber Cover | 20 | One-Way Valve Components |
| 8 | Screw M5×14 | 21 | Dual-Head Bolts M6×36 |
| 9 | Upper Crankcase | 22 | Hexagon Flange Bolt M6×12 |
| 10 | Washer 30×37×1 | 23 | Aluminium Gasket 6×13×2 |
| 11 | Oil Seal 15×35×5 | 24 | Oil Pan |
| 12 | Oil Gauge | 25 | Oil Level Sensor |
| 13 | Oil Gauge Gasket | 26 | Screw M6×18 |

FIG. B CRANKSHAFT PISTON

| No. | Description |
|-----|------------------------|
| 1 | Connecting Rod |
| 2 | Woodruff Key |
| 3 | Piston Pin Clip |
| 4 | Piston Pin |
| 5 | Needle Bearing K101414 |
| 6 | Piston |
| 7 | Piston Ring |

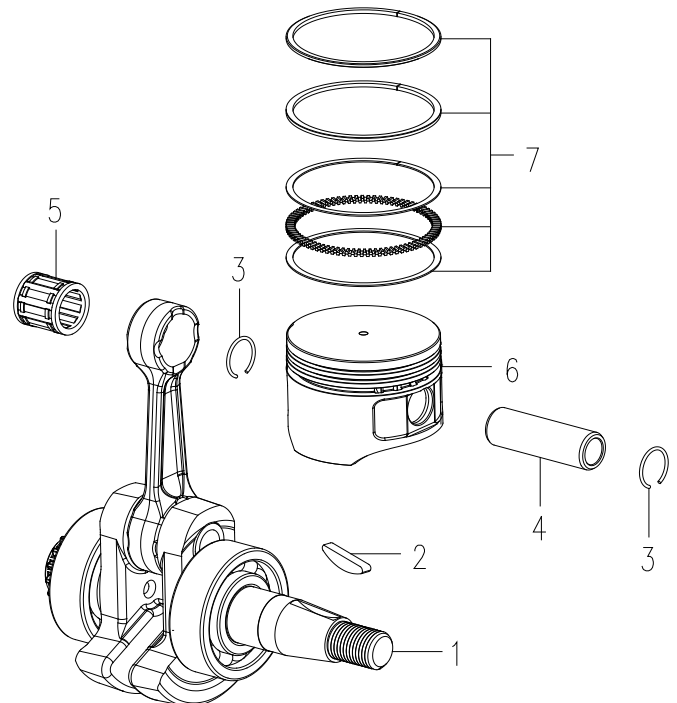

FIG. B CRANKSHAFT PISTON

Parts Diagram(IG950i)

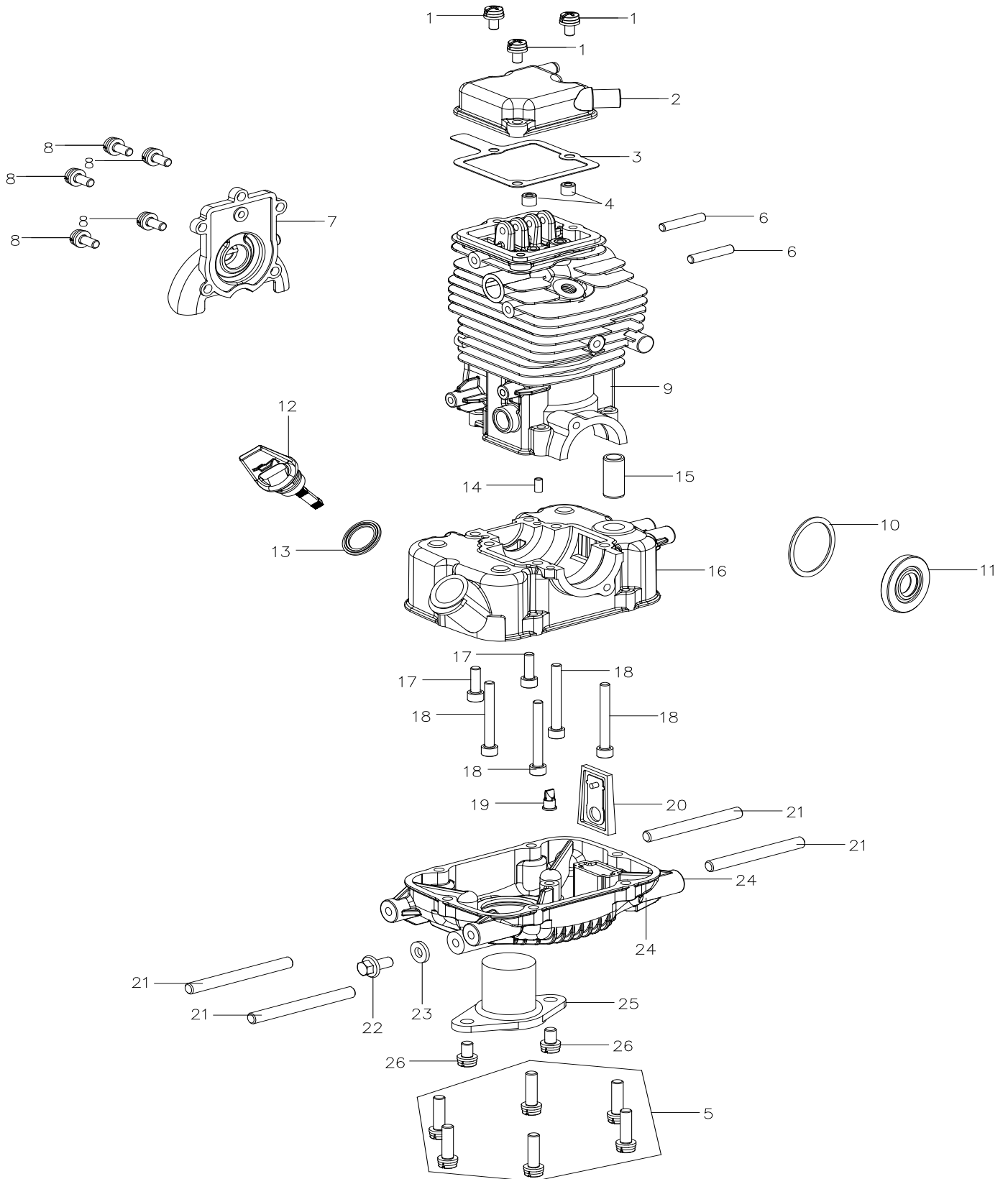

FIG. A CRANKCASE ASSY

Parts List / Parts Diagram(IG950i)

FIG. C CAMSHAFT

| No. | Description |
|-----|--------------------------------------------------------------------------------------|
| 1 | Dowel Bush |
| 2 | Rocker Gasket + Decompression of the pin + Torsional spring + Cover for cam |
| 3 | Pin4 g4×20 |
| 4 | Pin4 g6×30 |
| 5 | Lower Rocker |
| 6 | Tappet |
| 7 | Upper Rocker |
| 8 | Pin 5 g6×32 |
| 9 | Valve Spring Seat |
| 10 | Valve Spring |
| 11 | Intake Valve |
| 12 | Exhaust Valve |
| 13 | Rocker Gasket |

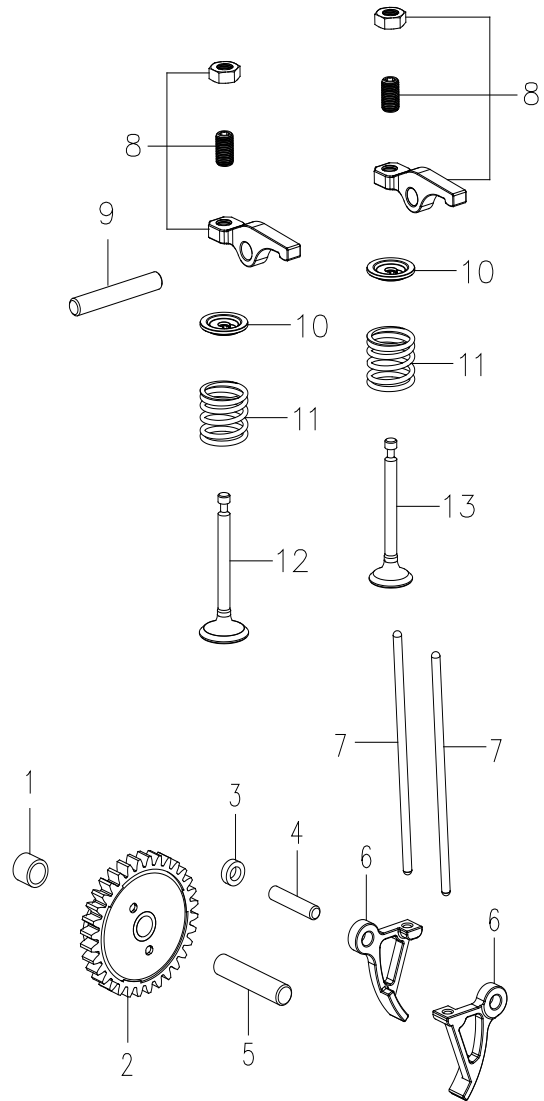

FIG. D LUBRICATION SYSTEM

| No. | Description |
|-----|---------------------------|
| 1 | Deaerator |
| 2 | Pipe Hoop 9 |
| 3 | Respiratory Tube |
| 4 | Outlet Tube |
| 5 | O Ring |
| 6 | Hexagon Flange Bolt M5×16 |
| 7 | Upper Oil Pipe |
| 8 | Pipe Hoop 13 |

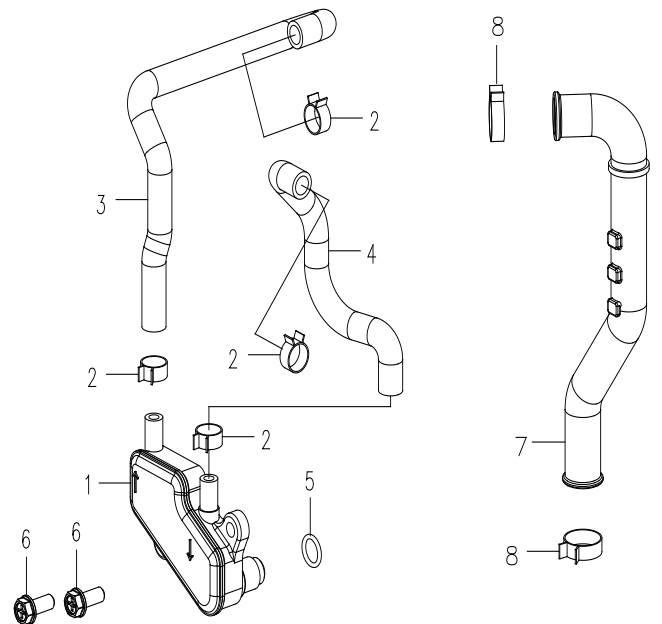

FIG. E AIR CLEANER

| No. | Description |
|-----|-----------------------------|
| 1 | Air Filter |
| 2 | Gasket of Air Filter |
| 3 | Gasket of Carburator |
| 4 | Hexagon Flange Bolts M5×22 |
| 5 | Insulation Board Components |
| 6 | Hexagon Flange Bolts M5×55 |
| 7 | Block rubber |
| 8 | Insulation Board Gasket |
| 9 | Fan Volute Bush |
| 10 | Hexagon Flange Bolts M5 |
| 11 | Tap Screw ST4.8×16-F.H |

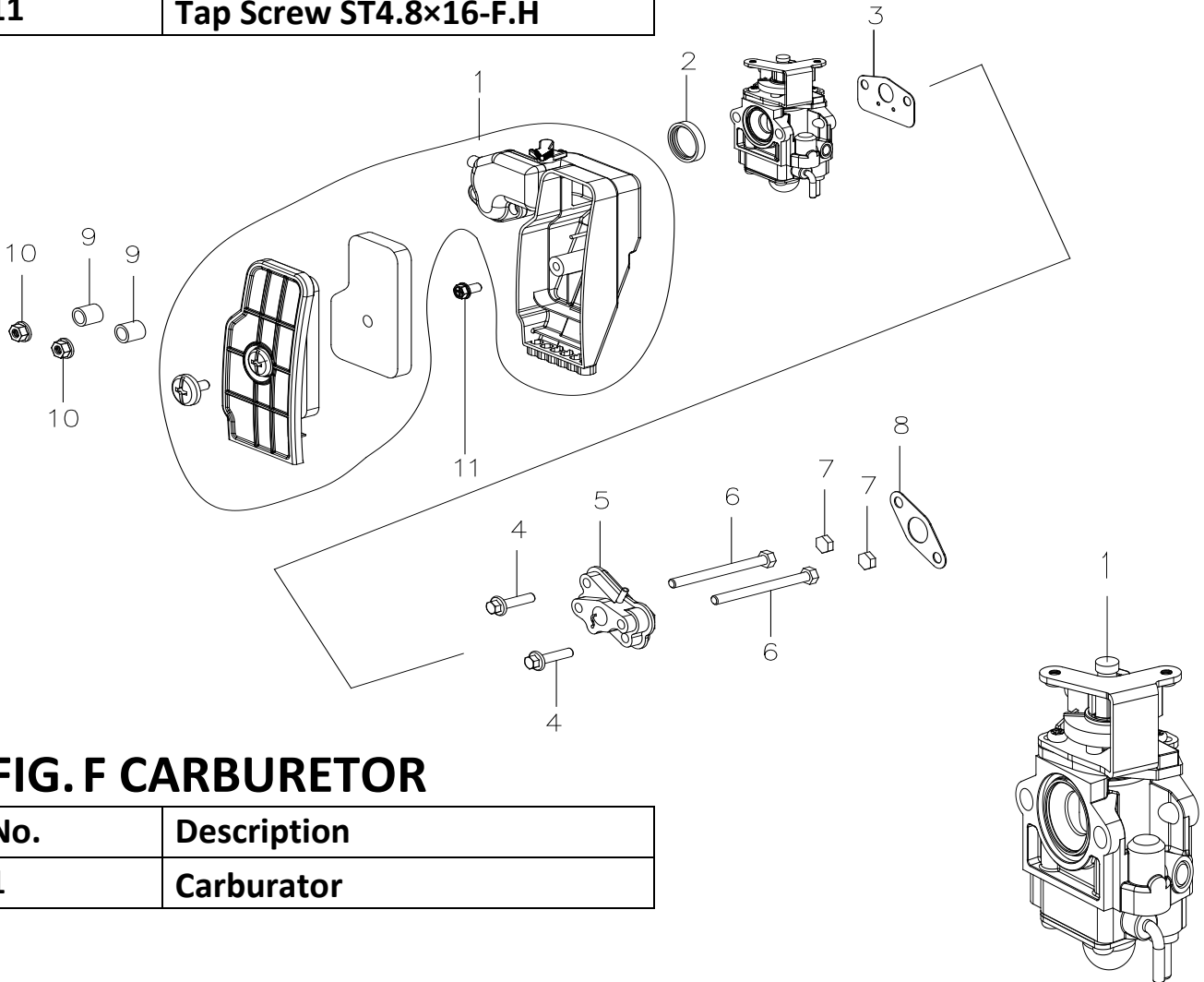

FIG. F CARBURETOR

| No. | Description |
|-----|-------------|
| 1 | Carburetor |

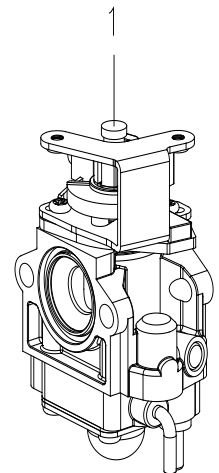
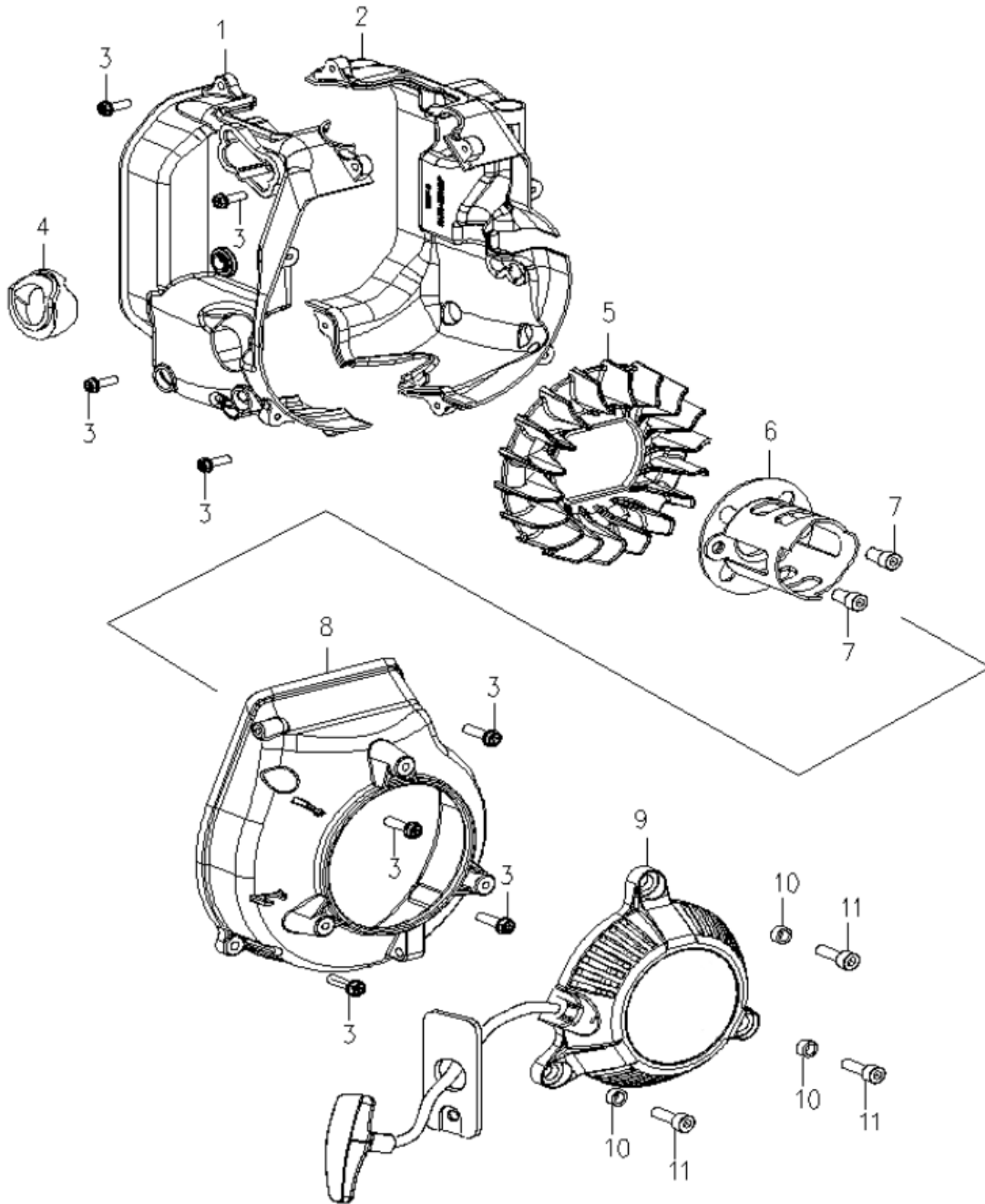

FIG.G RECOIL STARTER

| No. | Description | No. | Description |
|-----|------------------------------|-----|--------------------------------|
| 1 | Air Guide Sleeve A | 7 | Inner Hexagon Screw M6×10 |
| 2 | Air Guide Sleeve B | 8 | Fan Volute |
| 3 | Tap Screw ST4.8×16 | 9 | Recoil Starter +Handle+ Fender |
| 4 | Oil Filler Hole Airproof Pad | 10 | Recoil Starter Bush |
| 5 | Cooling Fan | 11 | Hexagon Flange Bolts M5×16 |
| 6 | Starting Hub | | |



Parts List / Parts Diagram(IG950i)

FIG.H MUFFLER

| No. | Description | No. | Description |
|-----|---------------------|-----|-----------------------|
| 1 | Bolt M6×35 | 5 | Muffler Gasket |
| 2 | Muffler | 6 | Muffler Pipe |
| 3 | Muffler Pipe Gasket | 7 | Washer 5 |
| 4 | Bolt M6×55 | 8 | Hexagon Flange Nut M5 |

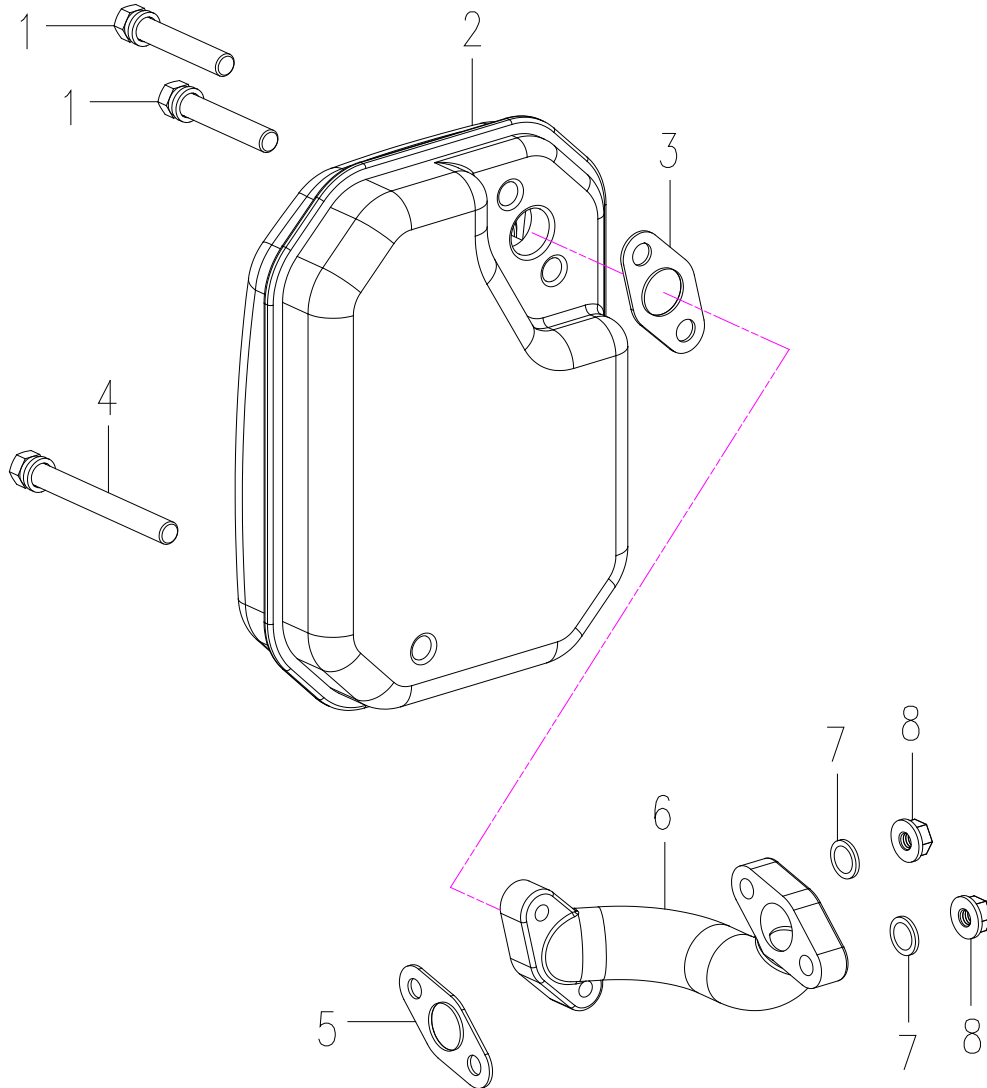

Parts List / Parts Diagram(IG950i)

FIG.I GENERATOR

| No. | Description | No. | Description |
|-----|-----------------------------|-----|----------------------------|
| 1 | Locating Plate | 7 | Hexagon Flange Bolts M5×10 |
| 2 | Stator 0.8KW 420V 580Hz | 8 | Trigger |
| | Bushing | 9 | Ignition Coil |
| 3 | Washer 5 | 10 | Tap Screw ST4.8×25-F.H |
| 4 | Hexagon Flange Bolts M5×35 | 11 | Ignition Coil Cap Seal |
| 5 | Rotor | 12 | Spark Plug CMR6A |
| 6 | Hexagon Flange Nut M10×1.25 | | |

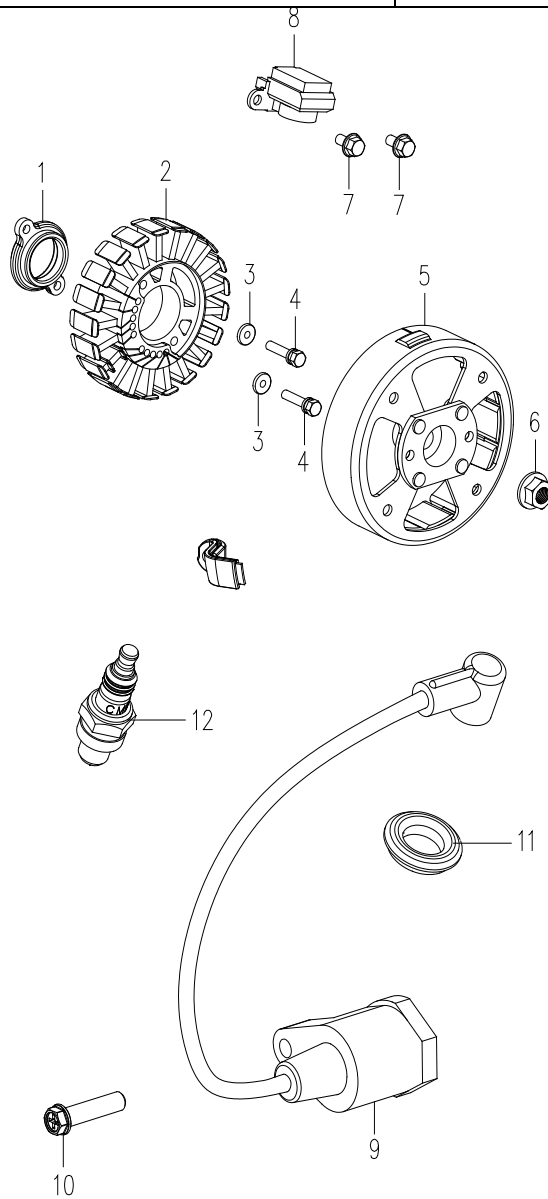
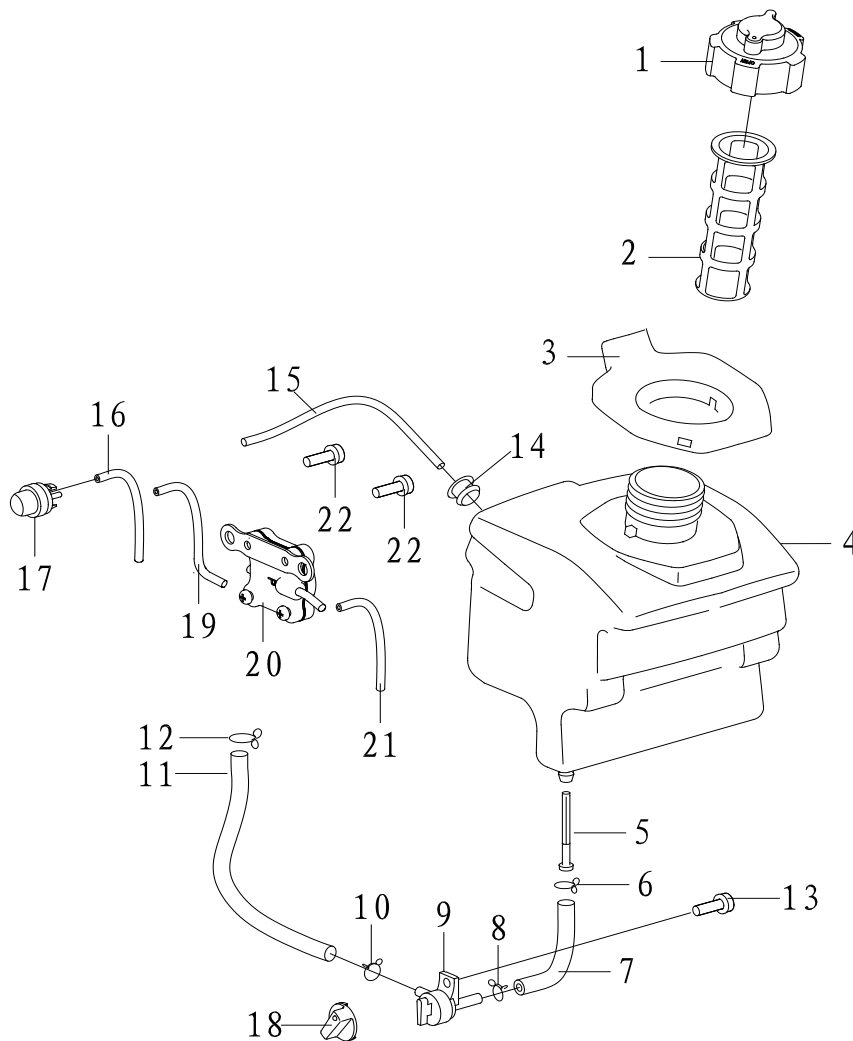

FIG.J FUEL TANK

| No. | Description | No. | Description |
|-----|-----------------------|-----|-------------------------------|
| 1 | Fuel Tank Cap Assy. | 13 | Tap Screw GB/T845 ST4.8×13-F |
| 2 | Fuel Tank Filter | 14 | Fuel-hole Plug |
| 3 | Fuel Tank Port Rubber | 15 | Fuel Hose 2.5×5×120 |
| 4 | Fuel Tank | 16 | Fuel Hose 2.5×5×80 |
| 5 | Fuel Outlet Filter | 17 | Fuel Lubricator |
| 6 | Steel Wire Clamp Ø11 | 18 | Fuel Cock Knob |
| 8 | Fuel Hose | 19 | Fuel Hose 2.5×5×95 |
| 9 | Steel Wire Clamp Ø10 | 20 | Negative pressure pump |
| 10 | Fuel Cock | 21 | Fuel Hose 2.5×5×110 |
| 11 | Steel Wire Clamp Ø9 | 22 | Tap Screw GB/T845 ST4.8×9.5-F |
| 12 | Fuel Hose 4.5×7.5×180 | | |



Parts List / Parts Diagram(IG950i)

FIG.K SHELL

| No. | Description | No. | Description |
|-----|----------------------------------------------|-----|-----------------------------------------------|
| 1 | Screw 4.8×13-F | 11 | Clamp |
| 2 | Right Side Cover | 12 | Muffler Cover |
| 3 | Fastener | 13 | Muffler Cover Seal |
| 4 | Right Cover of Shell | 14 | Screw GB/T9074.4 M5×18 |
| 5 | Edge Protection | 15 | Hexagon Nut M5 |
| 6 | Vibration Absorber | 16 | Cross Pan Head Screw M5×16 |
| 7 | Rubber Pad $\Phi 6 \times \Phi 16 \times 10$ | 17 | Rubber Pad $\Phi 6.5 \times \Phi 16 \times 2$ |
| 8 | Left Cover of Shell | 18 | Lock Nut GB/T6187 M6 |
| 9 | Upper Cover | 19 | Tap Screw GB/T845 ST4.8×9.5-F |
| 10 | Left Side Cover | 20 | Panel Box |

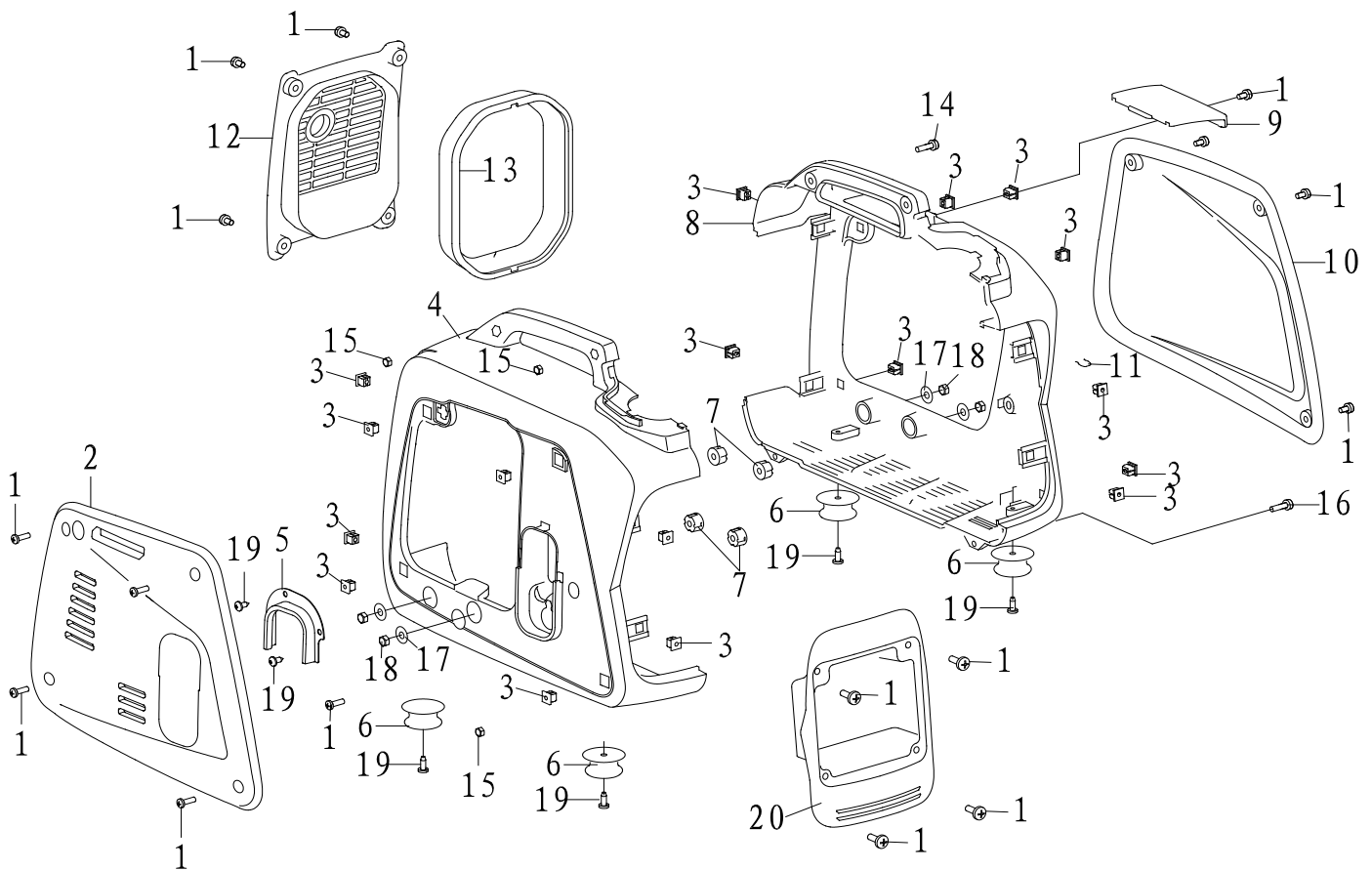

Parts List / Parts Diagram(IG950i)

FIG.L GOVERNOR

| No. | Description |
|-----|------------------|
| 1 | Stepper Motor |
| 2 | Drive Arm |
| 3 | Drive Arm Spring |
| 4 | Screw M4×6 |
| 5 | Spring Washer 4 |

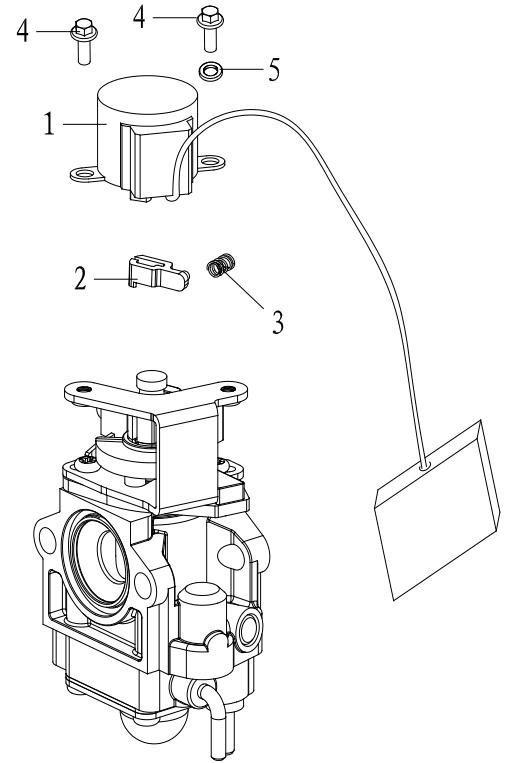
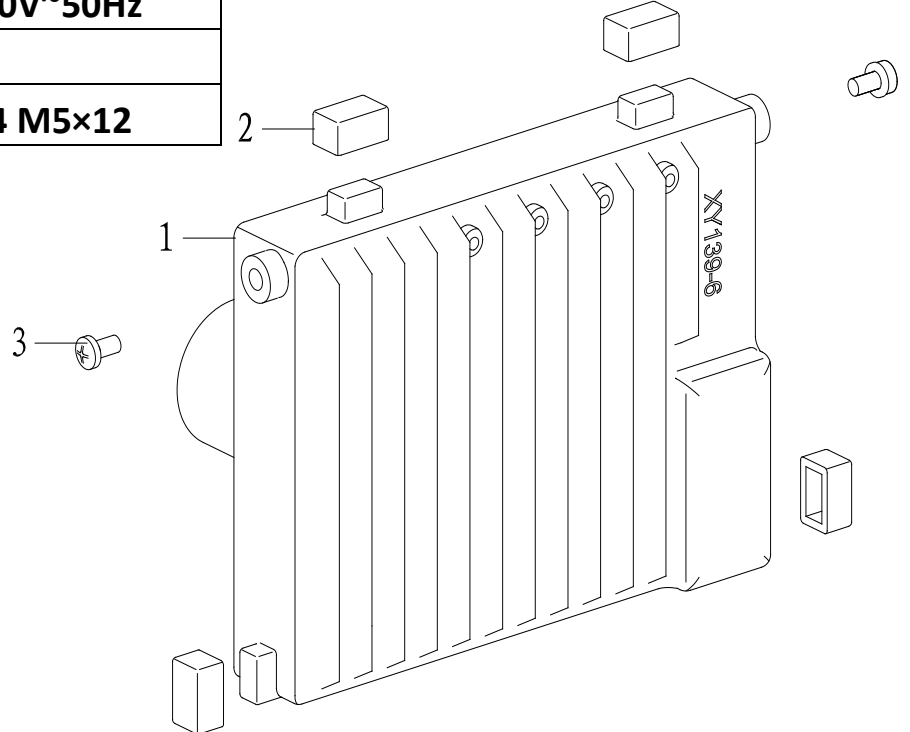

FIG.M INVERTER

| No. | Description |
|-----|--------------------------|
| 1 | Inverter 0.7Kw 230V~50Hz |
| 2 | Inverter Gasket |
| 3 | Screw GB/T9074.4 M5×12 |



Parts List / Parts Diagram(IG950i)

FIG.N CONTROL PANEL

| No. | Description | No. | Description |
|-----|------------------------------|-----|-----------------------------------------------|
| 1 | Cross Pan Head Screw M5×16 | 11 | Clamp |
| 2 | Ignition Control Module | 12 | Muffler Cover |
| 3 | Overload Protector 4.5A | 13 | Muffler Cover Seal |
| 4 | Cross Pan Head Screw M5×16 | 14 | Screw GB/T9074.4 M5×18 |
| 5 | Rectifier KBPC3502 | 15 | Hexagon Nut M5 |
| 6 | Hexagon Flange Nut M4 | 16 | Cross Pan Head Screw M5×16 |
| 7 | Flange Bolt GB/16674 M5×16 | 17 | Rubber Pad $\Phi 6.5 \times \Phi 16 \times 2$ |
| 8 | Lock Gasket GB862.2 $\phi 5$ | 18 | Lock Nut GB/T6187 M6 |
| 9 | Panel Components | 19 | Tap Screw GB/T845 ST4.8×9.5-F |
| 10 | Panel Sticker | 20 | Panel Box |
| 11 | Hexagon Flange Nut M5 | | |

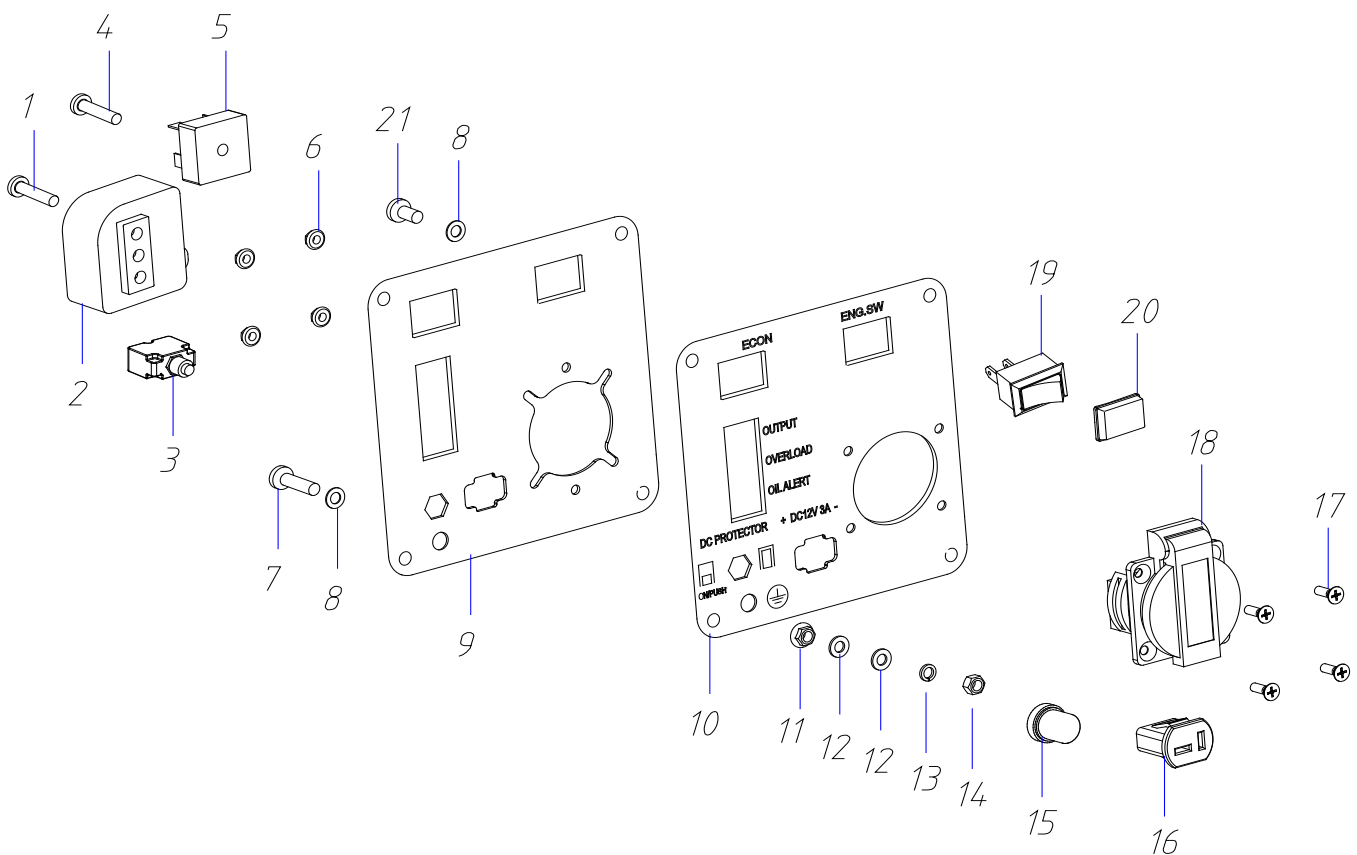

CE DECLARATION OF CONFORMITY

TOOLSAVE

Unit C, Manders Ind. Est.,
Old Heath Road, Wolverhampton,
WV1 2RP.
Tel: 01902 450 470

Declares that the Inverter Generator (IG1200i)

Is in compliance with the regulations included in the Directives:2014/30/EU

EC DECLARATION OF CONFORMITY

Certificate for EC-type examination delivered by Interk Testing Services Hangzhou 16
No. 1 Ave., Xiasha Economic Development District, Hangzhou 310018, China
(Verification No.:160400545HZH-V1)

Person who declares: Bill Evans

CE

17/05/21

The Director



FIG.A CRANKCASE ASSY

| No. | Description | No. | Description |
|-----|--------------------------|-----|---------------------------|
| 1 | Screw M5×20 | 14 | Lower Crankcase |
| 2 | Cylinder Head Cover | 15 | Screw M6×22 |
| 3 | Cylinder Head Cover Seal | 16 | Screw M6×45 |
| 4 | Valve Oil Seal | 17 | Rubber One-Way Valve |
| 5 | Dual-Head Bolts M5×85 | 18 | One-Way Valve Components |
| 6 | Dual-Head Bolts M5×28 | 19 | Dual-Head Bolts M6×36 |
| 7 | Cam Chamber Cover | 20 | Hexagon Flange Bolt M6×12 |
| 8 | Upper Crankcase | 21 | Aluminium Gasket 6×13×2 |
| 9 | Oil Seal 17×27×6 | 22 | Oil Pan |
| 10 | Oil Gauge | 23 | Oil Lever Sensor |
| 11 | Oil Gauge Gasket | 24 | Screw M6×18 |
| 12 | Dowel Pin 4×8 | 25 | Screw M5×25 |
| 13 | Ventilation Nozzle | | |

FIG. B CRANKSHAFT PISTON

| No. | Description |
|-----|------------------------|
| 1 | Connecting Rod |
| 2 | Woodruff Key |
| 3 | Piston Pin Clip |
| 4 | Piston Pin |
| 5 | Needle Bearing K101413 |
| 6 | Piston |
| 7 | Piston Ring |

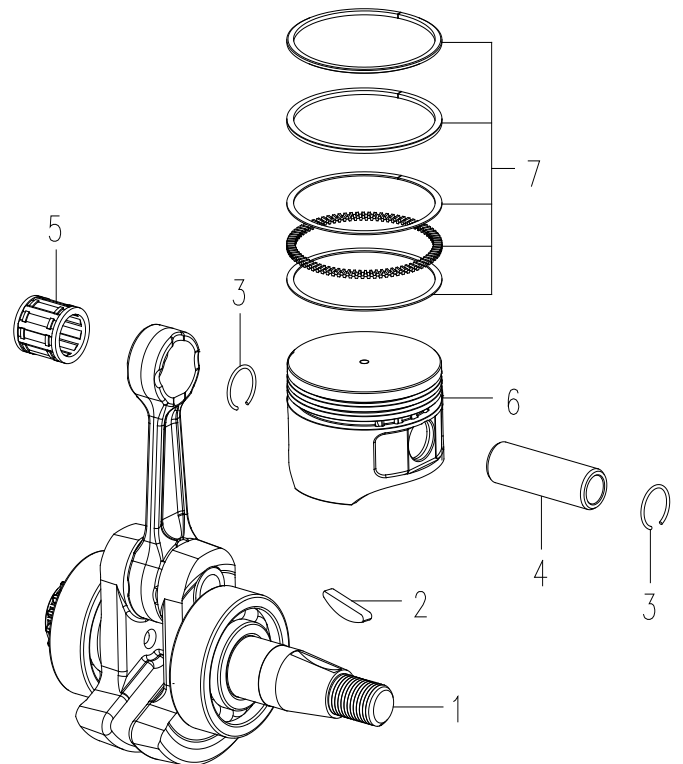

FIG. B CRANKSHAFT PISTON

Parts Diagram

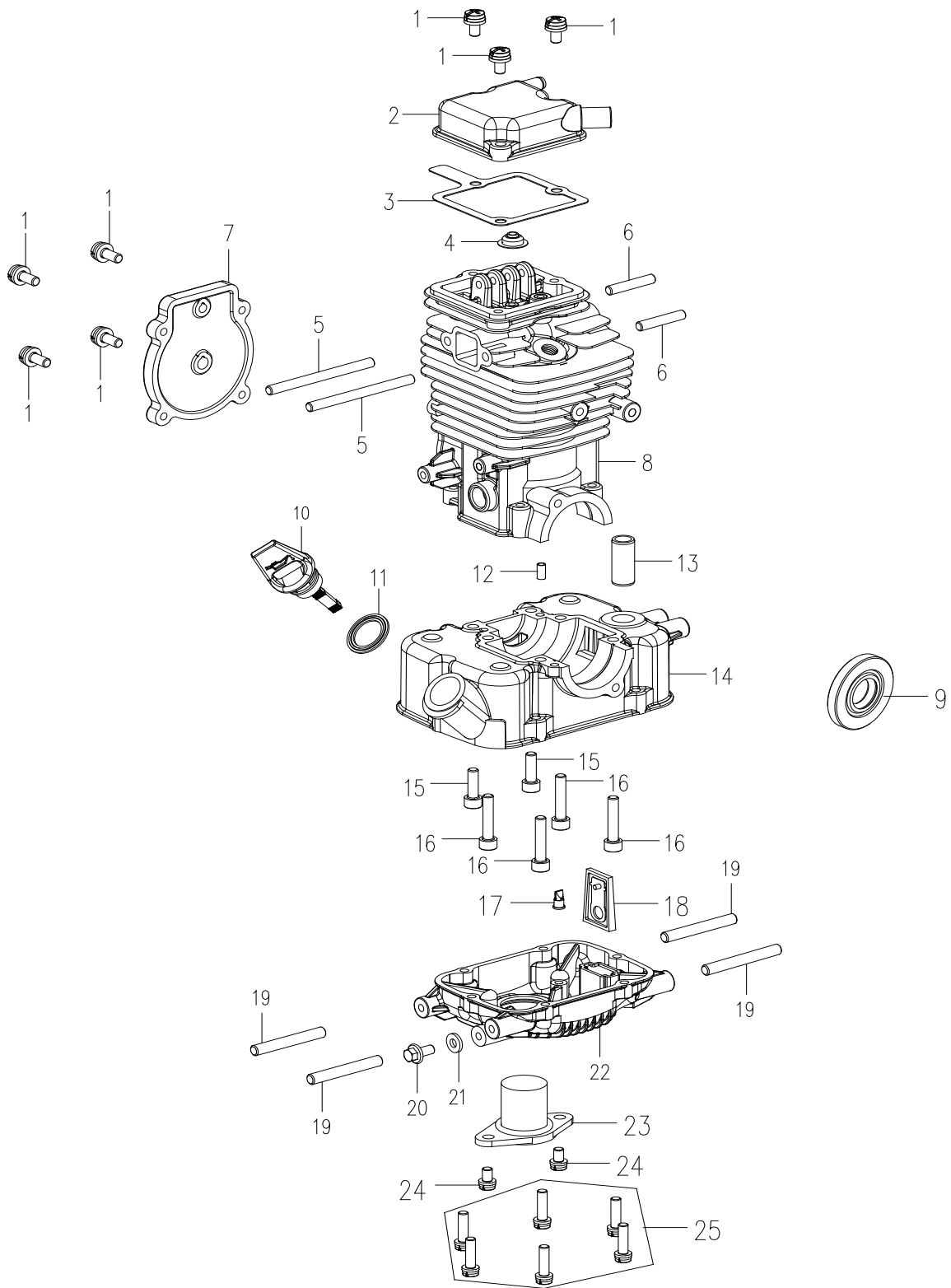

FIG. A CRANKCASE ASSY

FIG. C CAMSHAFT

| No. | Description |
|-----|---------------------------------------------------------------------------------|
| 1 | Dowel Bush |
| 2 | Camshaft + Decompression of the pin + Torsional spring + Cover for cam |
| 3 | Rocker Gasket |
| 4 | Pin4 g4×30 |
| 5 | Pin4 g7×34 |
| 6 | Lower Rocker |
| 7 | Tappet |
| 8 | Upper Rocker |
| 9 | Pin 5 g5×34 |
| 10 | Valve Spring Seat |
| 11 | Valve Spring |
| 12 | Intake Valve |
| 13 | Exhaust Valve |

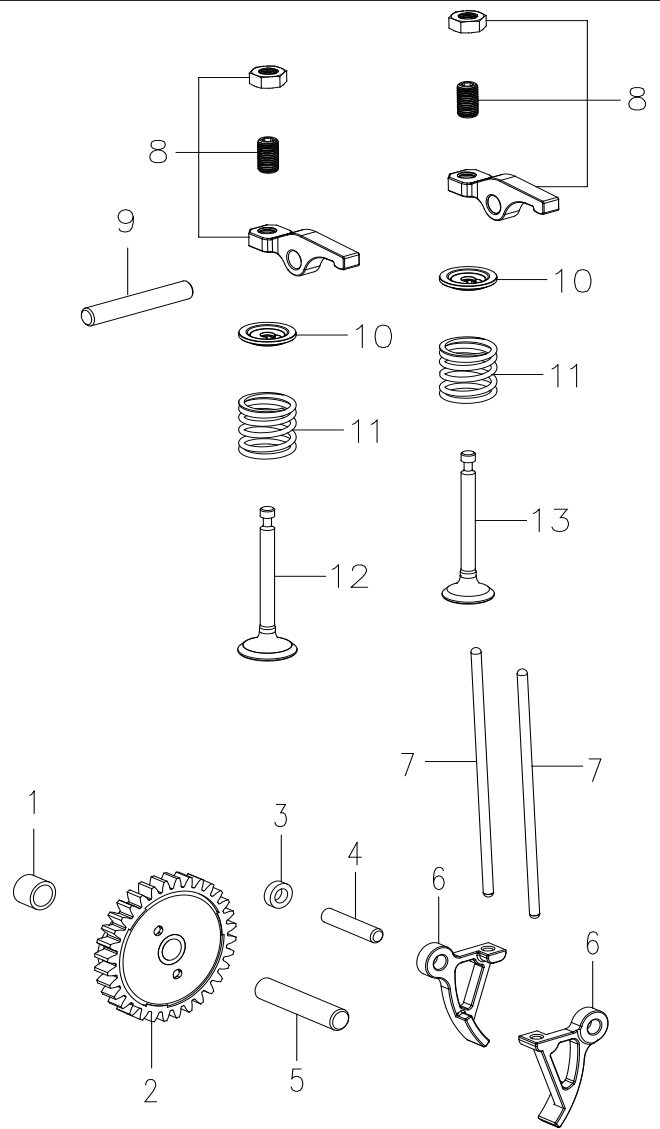

FIG. D LUBRICATION SYSTEM

| No. | Description |
|-----|---------------------------|
| 1 | Deaerator |
| 2 | Pipe Hoop 8/ 9 |
| 3 | Respiratory Tube |
| 4 | Outlet Tube |
| 5 | O Ring |
| 6 | Hexagon Flange Bolt M5×16 |
| 7 | Upper Oil Pipe |
| 8 | Pipe Hoop 13 |

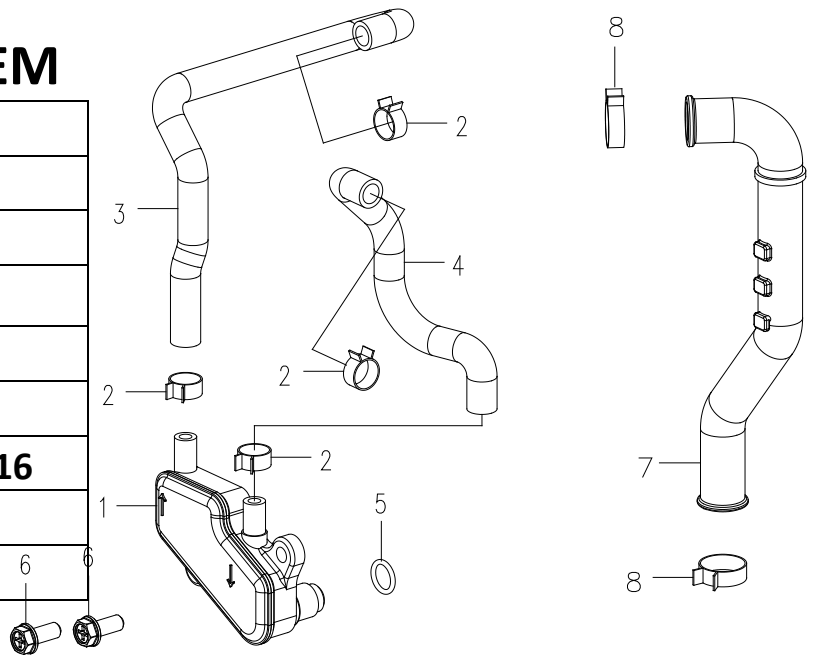

FIG. E AIR CLEANER

| No. | Description |
|-----|-----------------------------------|
| 1 | Insulation Board Gasket |
| 2 | Small Insulation Board Components |
| 3 | Insulation Gasket |
| 4 | Insulation Board Components |
| 5 | Carburator Gasket |
| 6 | Air Cleaner Gasket |
| 7 | Air Cleaner Assy. |
| 8 | Fan Volute Bush |
| 9 | Hexagon Flange Bolts M5 |
| 10 | Tap Screw ST4.8×16-F.H |

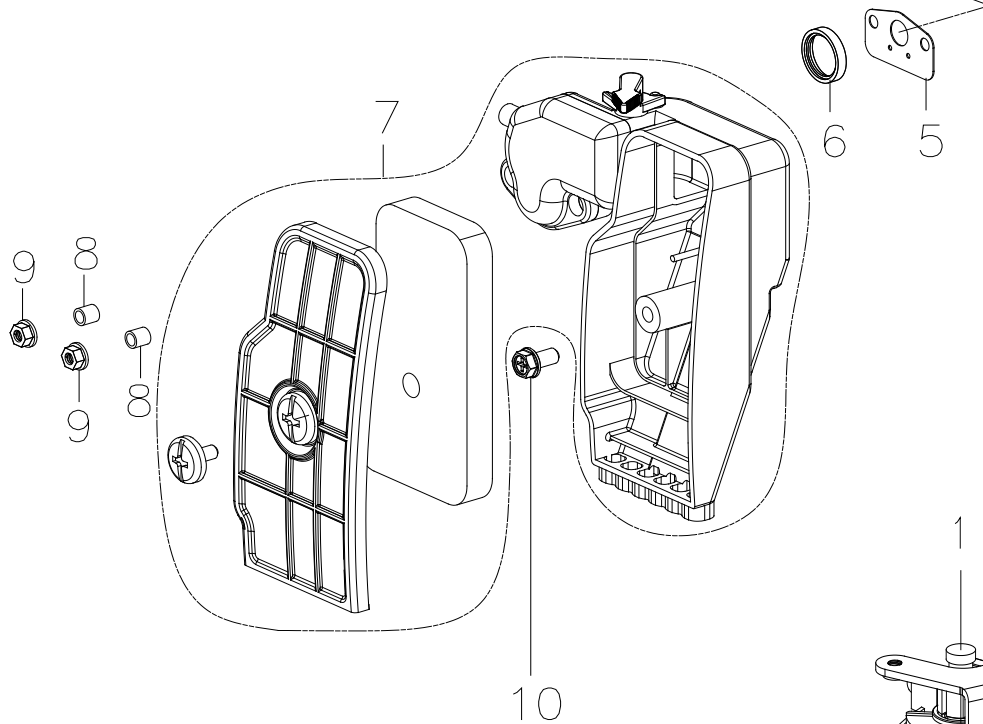
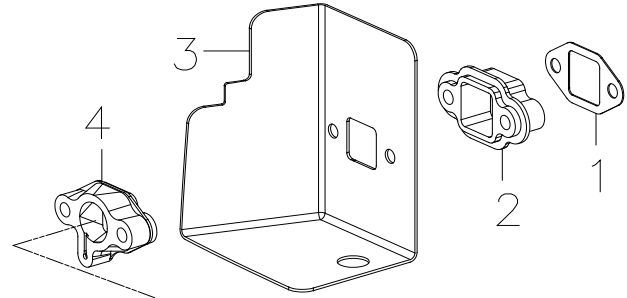

FIG. F CARBURETOR

| No. | Description |
|-----|-------------|
| 1 | Carburator |

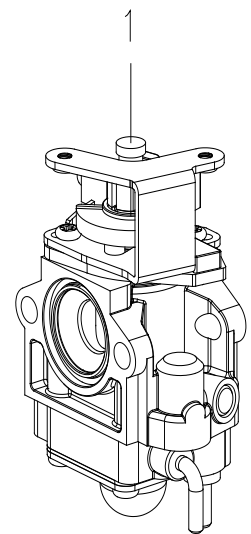

FIG.G RECOIL STARTER

| No. | Description | No. | Description |
|-----|------------------------------|-----|----------------------------------------|
| 1 | Air Guide Sleeve A | 8 | Inner Hexagon Screw M6×10 |
| 2 | Air Guide Sleeve B | 9 | Starting Hub |
| 3 | Tap Screw ST4.8×16-F.H | 10 | Fan Volute |
| 4 | Oil Filler Hole Airproof Pad | 11 | Recoil Starter Parts + handle + Fender |
| 5 | Cooling Fan | 12 | Recoil Starter Bush |
| 6 | Inner Hexagon Screw M8×25 | | Hexagon Flange Bolts M5×16 |
| 7 | Starting Hub Seat | | |

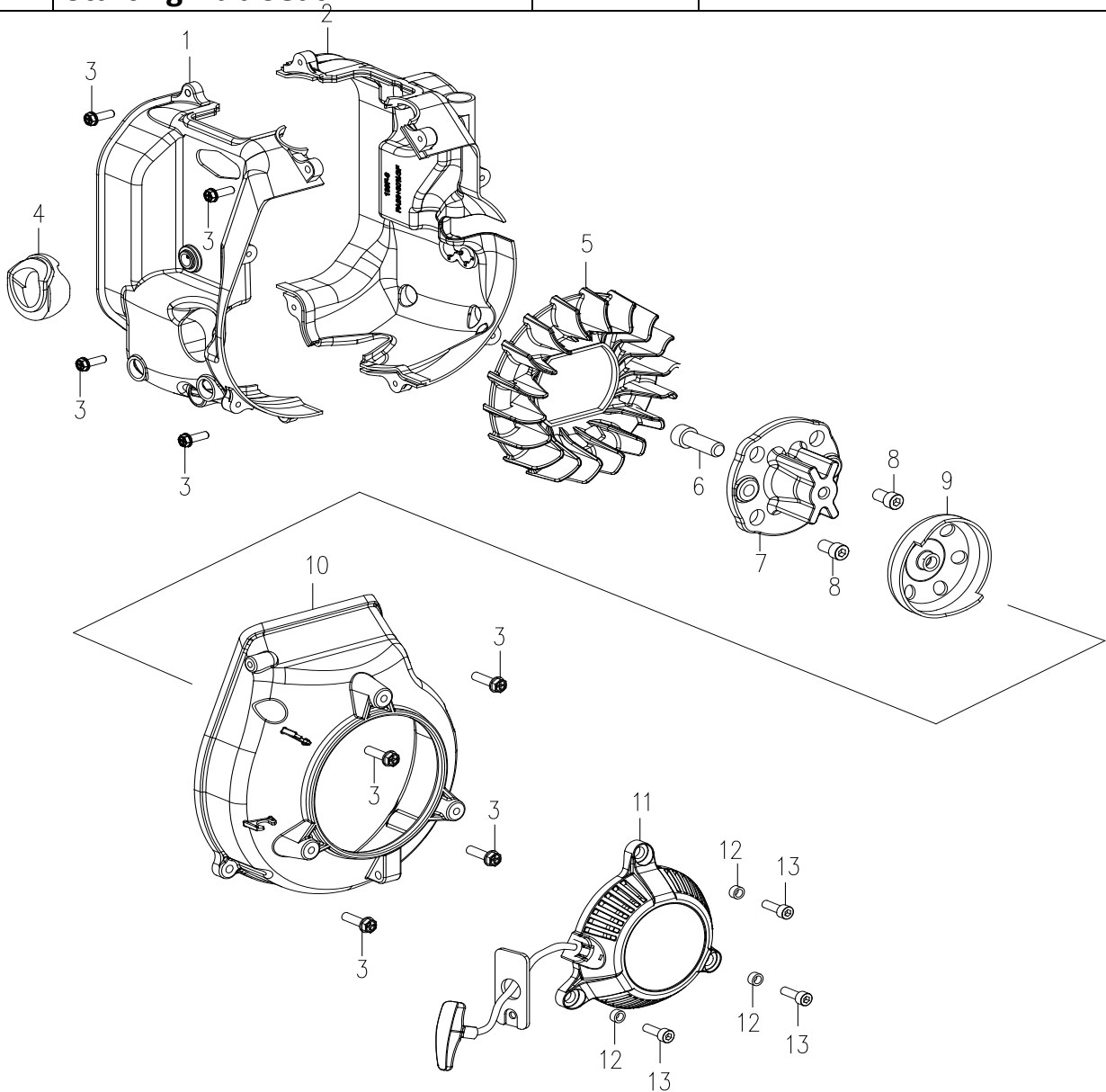

FIG.H MUFFLER

| No. | Description | No. | Description |
|-----|---------------------|-----|-----------------------|
| 1 | Bolt M6×45 | 5 | Muffler Gasket |
| 2 | Muffler Assy. | 6 | Muffler Pipe |
| 3 | Muffler Pipe Gasket | 7 | Washer 5 |
| 4 | Bolt M6×70 | 8 | Hexagon Flange Nut M5 |

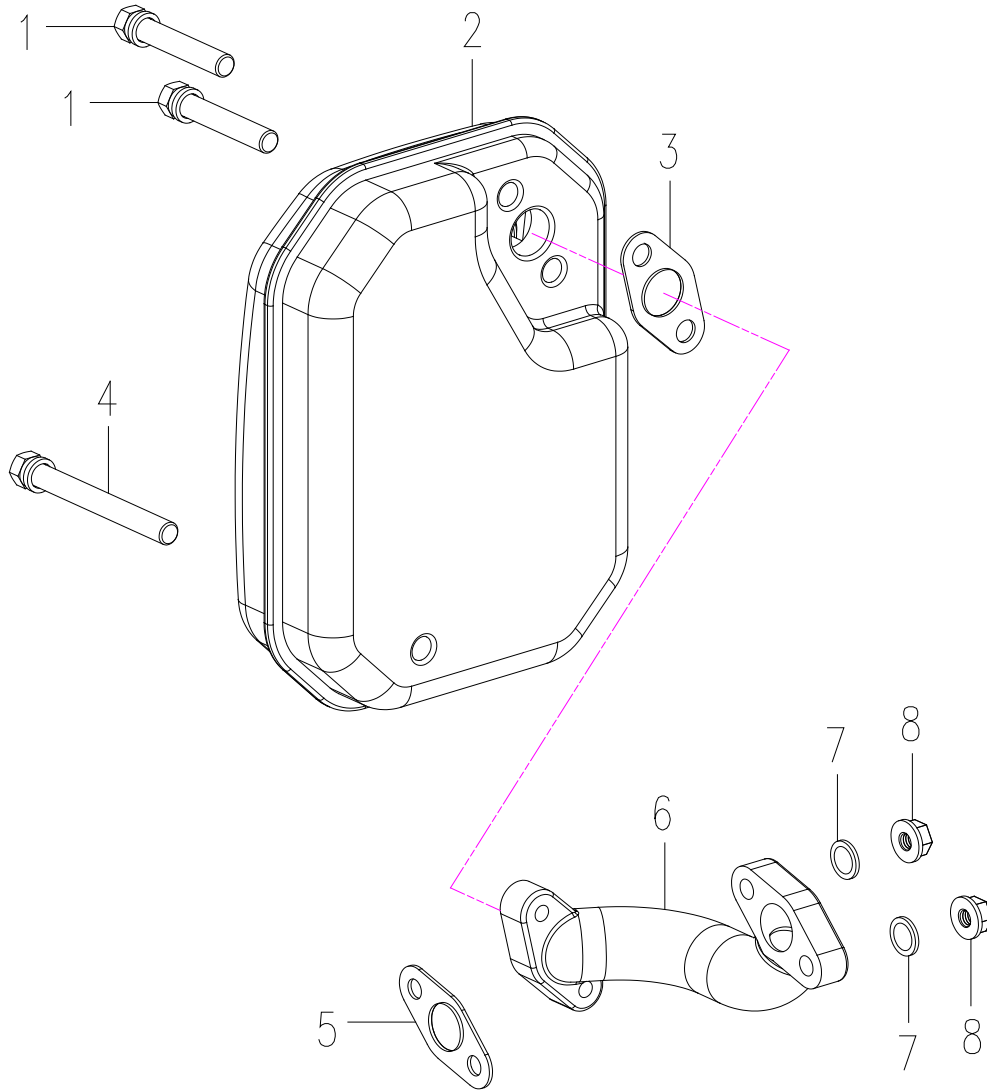

FIG.I GENERATOR

| No. | Description | No. | Description |
|-----|-----------------------------------|-----|-------------------------------|
| 1 | Stator 1.0KW 420V 580Hz + bushing | 7 | Trigger |
| 2 | Washer 5 | 8 | Ignition Coil |
| 3 | Hexagon Flange Bolts M5x30 | 9 | Tap Screw ST4.8x25-F.H |
| 4 | Rotor | 10 | Ignition Coil Cap With Shield |
| 5 | Hexagon Flange Nut M10x1.25 | 11 | Spark Plug A5RTC |
| 6 | Hexagon Flange Bolts M5x10 | | |

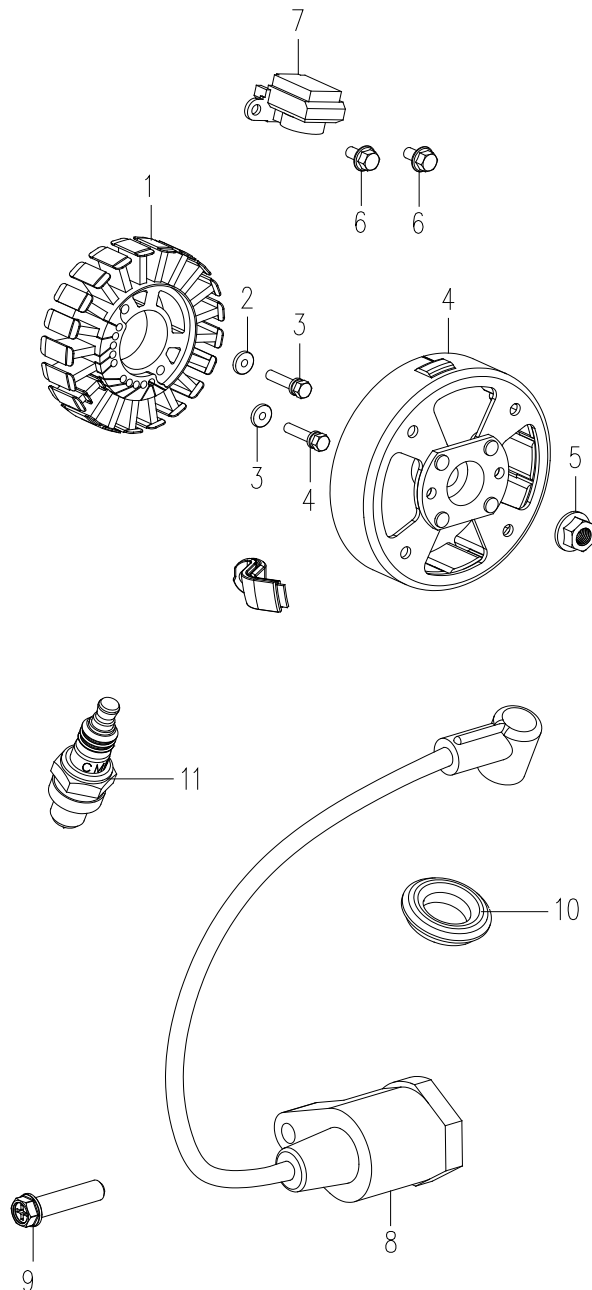

FIG.J FUEL TANK

| No. | Description | No. | Description |
|-----|-----------------------------------|-----|----------------------------------|
| 1 | Fuel Tank Cap Assy. | 10 | Steel Wire Clamp $\varnothing 9$ |
| 2 | Fuel Tank Filter | 11 | Fuel Hose 4.5×7.5×200 |
| 3 | Fuel Tank Port Rubber | 12 | Clamp $\varnothing 8$ |
| 4 | Fuel Tank | 13 | Tap Screw GB/T845 ST4.8×13-F |
| 5 | Fuel Outlet Filter | 14 | Fuel-hole Plug |
| 6 | Steel Wire Clamp $\varnothing 11$ | 15 | Fuel Hose 2.5×5×190 |
| 7 | Fuel Hose | 16 | Fuel Hose 2.5×5×80 |
| 8 | Steel Wire Clamp $\varnothing 10$ | 17 | Fuel Lubricator |
| 9 | Fuel Cock | 18 | Fuel Cock Knob |

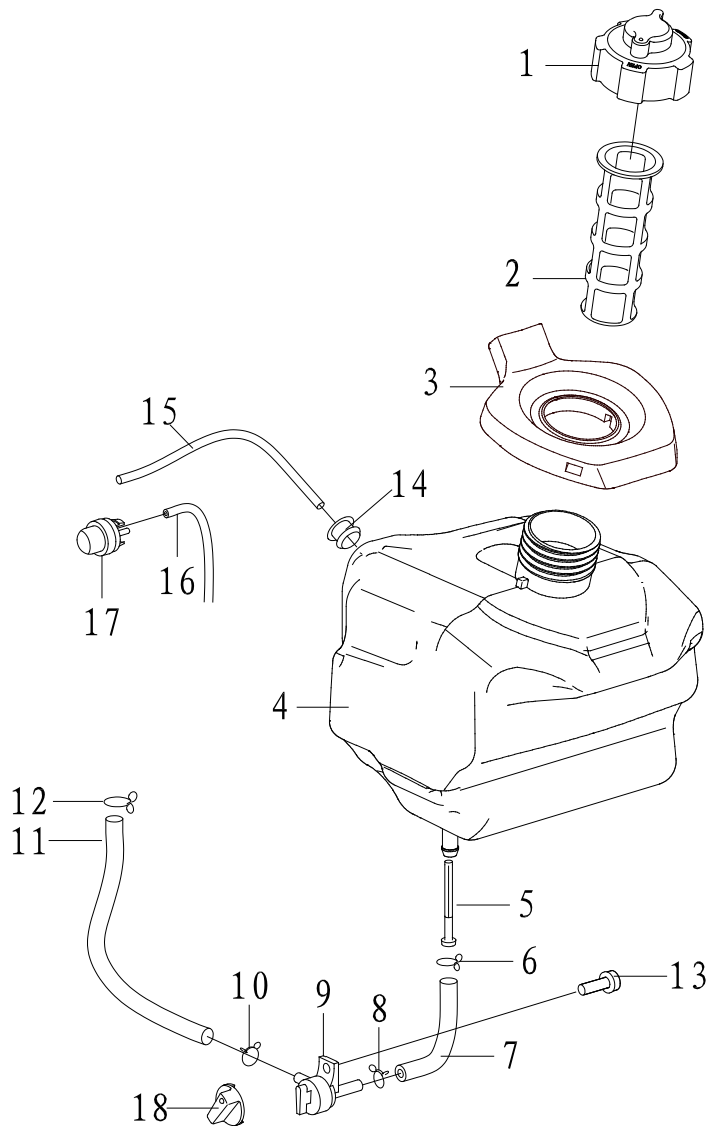

FIG.K SHELL

| No. | Description | No. | Description |
|-----|----------------------------------------------|-----|-----------------------------------------------|
| 1 | Screw ST4.8×13-F | 11 | Clamp |
| 2 | Right Side Cover | 12 | Muffler Cover |
| 3 | Fastener | 13 | Muffler Cover Seal |
| 4 | Right Cover of Shell | 14 | Screw GB/T9074.4 M5×18 |
| 5 | Edge Protection | 15 | Hexagon Nut M5 |
| 6 | Vibration Absorber | 16 | Cross Pan Head Screw M5×16 |
| 7 | Rubber Pad $\Phi 6 \times \Phi 16 \times 10$ | 17 | Rubber Pad $\Phi 6.5 \times \Phi 16 \times 2$ |
| 8 | Left Cover of Shell | 18 | Lock Nut GB/T6187 M6 |
| 9 | Upper Cover | 19 | Tap Screw GB/T845 ST4.8×9.5-F |
| 10 | Left Side Cover | 20 | Panel Box |

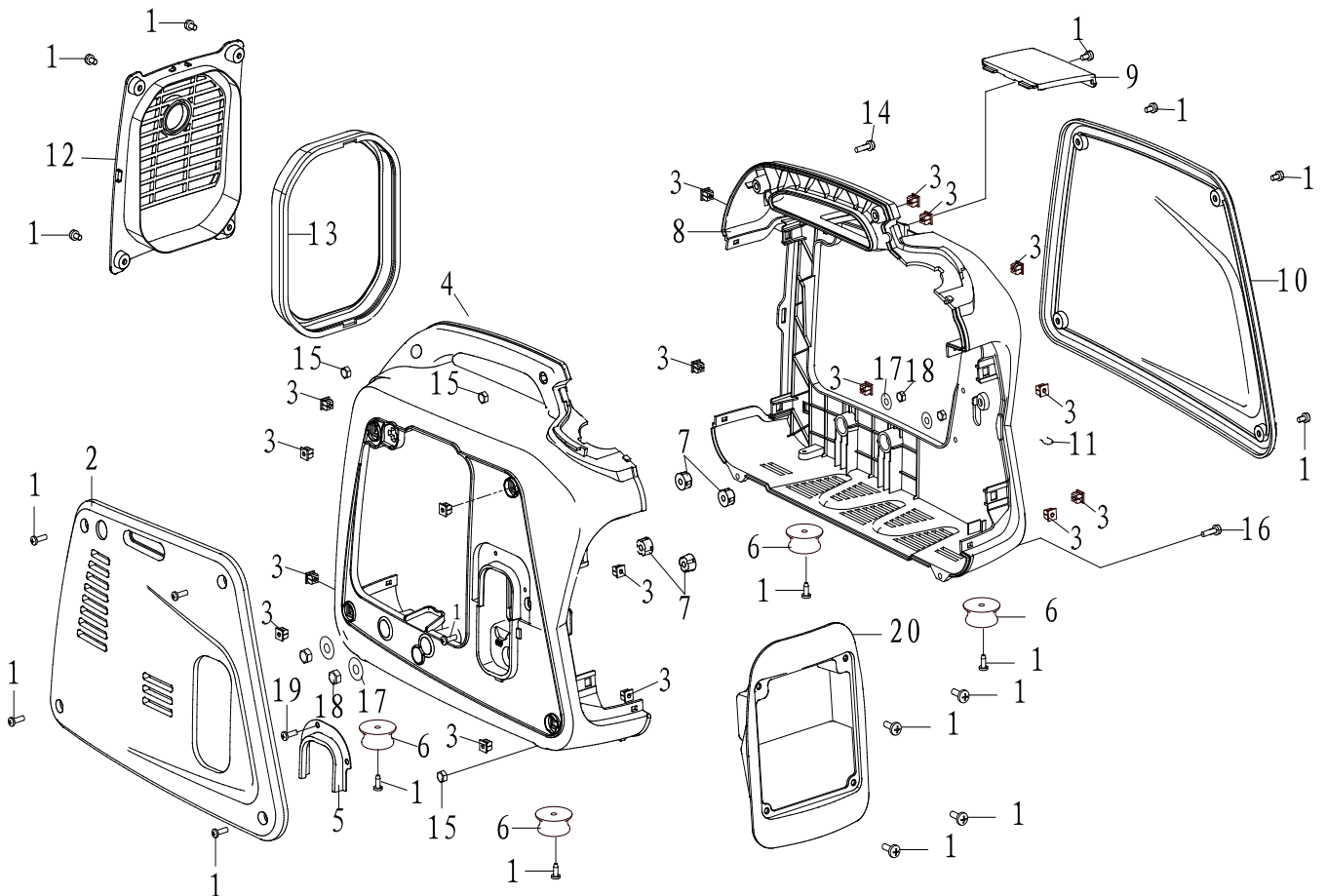

FIG.L GOVERNOR

| No. | Description |
|-----|------------------|
| 1 | Stepper Motor |
| 2 | Drive Arm |
| 3 | Drive Arm Spring |
| 4 | Screw M4×6 |
| 5 | Spring Washer 4 |

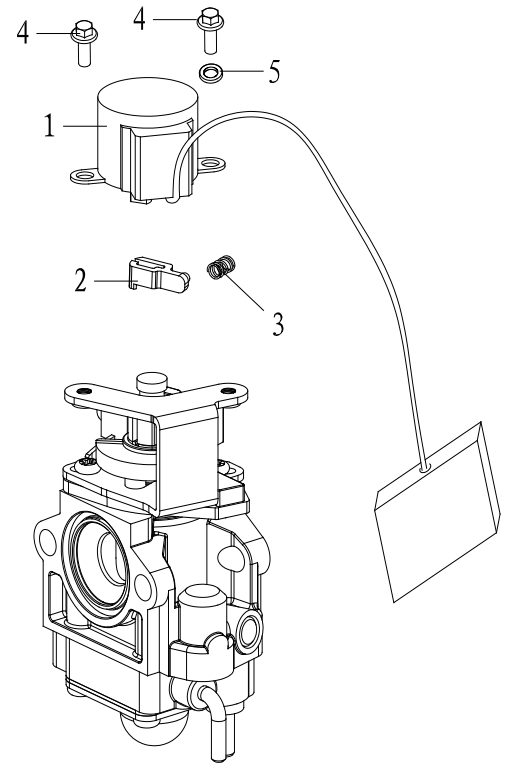

FIG.M INVERTER

| No. | Description |
|-----|-------------------------|
| 1 | Inverter 1.0kw 230V50HZ |
| 2 | Inverter Gasket |
| 3 | Screw GB/T9074.4 M5×12 |
| 4 | Inverter Bottom Gasket |

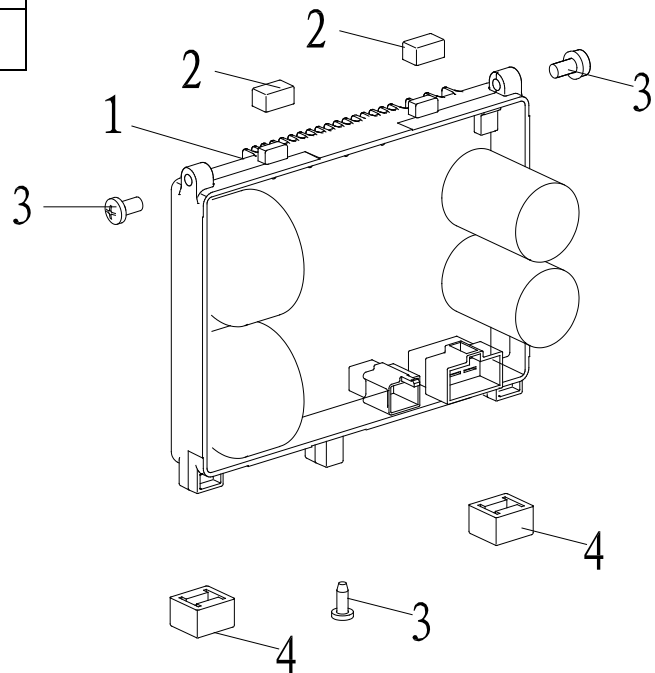
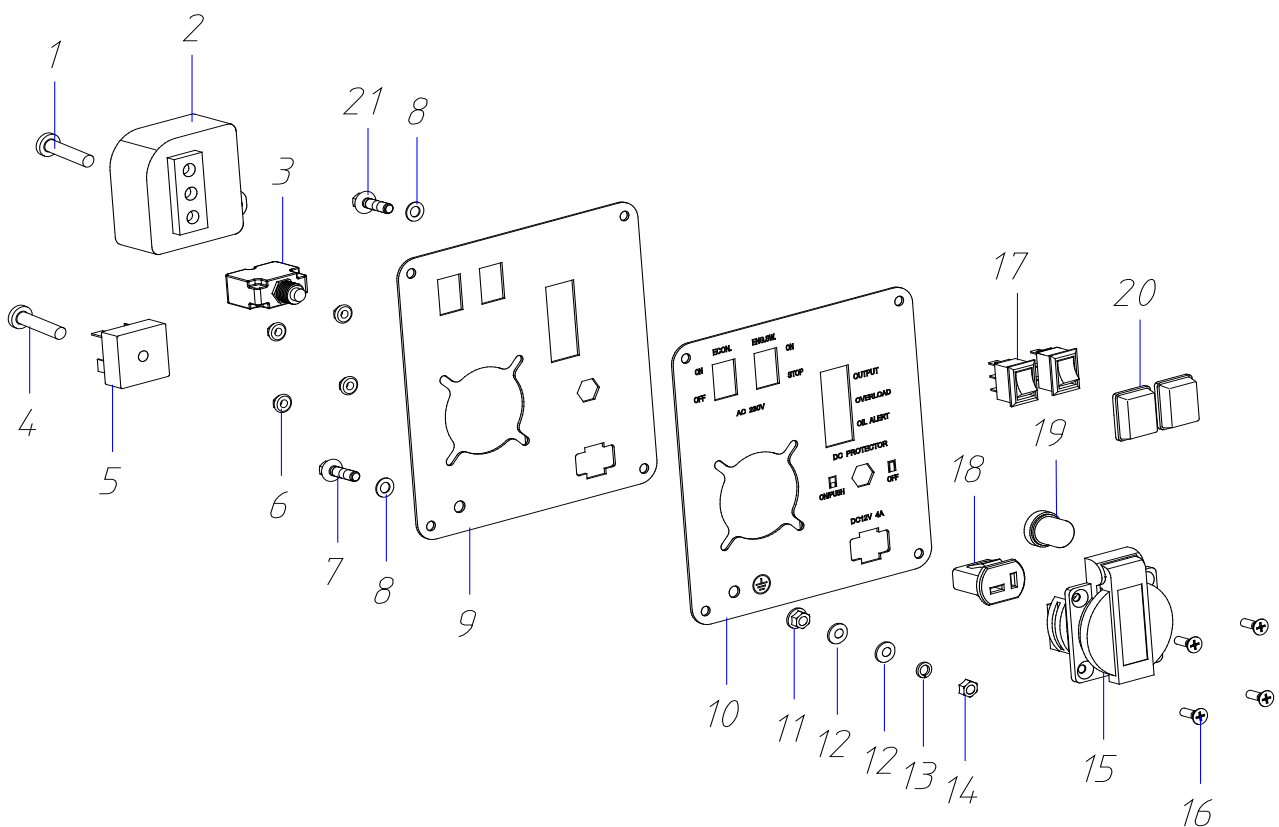

FIG.N CONTROL PANEL

| No. | Description | No. | Description |
|-----|----------------------------|-----|------------------------------------|
| 1 | Cross Pan Head Screw M5×16 | 11 | Washer GB/T97 φ5 |
| 2 | Ignition Controller | 12 | Spring Washer GB/T93 φ5 |
| 3 | Overload Protector 4.5A | 13 | Hexagon Flange Nut M5 |
| 4 | Screw M5×16 | 14 | European Socket |
| 5 | Rectifier KBPC3502 | 15 | Countersunk Head Screw M4×12 |
| 6 | Hexagon Flange Nut M4 | 16 | Boat Switch |
| 7 | Flange Bolt GB/16674 M5×16 | 17 | DC Charging Socket </td |
| 8 | Lock Gasket GB862.2 φ5 | 18 | Overload Protector, Waterproof Cap |
| 9 | Panel Components | 19 | Boat Switch, Waterproof Cap |
| 10 | Panel Sticker | 20 | Screw M5×8 |
| 11 | Hexagon Flange Nut M5 | 21 | Washer GB/T97 φ5 |



CE DECLARATION OF CONFORMITY

TOOLSAVE

Unit C, Manders Ind. Est.,
Old Heath Road, Wolverhampton,
WV1 2RP.
Tel: 01902 450 470

Declares that the Inverter Generator (IG2000i)

Is in compliance with the regulations included in the Directives:2014/30/EU

EC DECLARATION OF CONFORMITY

Certificate for EC-type examination delivered by Interk Testing Services Hangzhou 16
No. 1 Ave., Xiasha Economic Development District, Hangzhou 310018, China
(Verification No.: 160400545HZH-V1)

Person who declares: Bill Evans

CE

17/05/21

The Director



FIG.A CRANKCASE ASSY

| No. | Description | No. | Description |
|-----|-----------------------------|-----|-----------------------------------|
| 1 | Screw M6×18 | 16 | Oil Gauge |
| 2 | Ventilation Nozzle | 17 | O ring 19*3.55 |
| 3 | Cylinder Head Cover | 18 | Lower Crankcase |
| 4 | Cylinder Head Cover Seal | 19 | Inner Hexagon ScrewGB/T70.1 M6×25 |
| 5 | Valve Oil Seal | 20 | Inner Hexagon ScrewGB/T70.1 M8×55 |
| 6 | Screw M5×20 | 21 | Oil Seal 21×32×5 |
| 7 | Cam Chamber Cover | 22 | Oil Pan |
| 8 | Dual-Head Bolts M5×100 | 23 | Hexagon Flange Bolt M6×12 |
| 9 | Upper Crankcase | 24 | Aluminium Gasket 6×13×2 |
| 10 | Dual-Head Bolts M6×32 | 25 | Oil Lever Sensor |
| 11 | Dual-Head Bolts M5×76 | 26 | Screw M6×18 |
| 12 | Countersunk Head Screw M3×5 | 27 | Dual-Head Bolts M6×36 |
| 13 | Limiting Board | 28 | One-Way Valve Components |
| 14 | Valve Plate | 29 | Stud M6*36 |
| 15 | Dowel Pin 4×8 | | |

FIG. B CRANKSHAFT PISTON

| No. | Description |
|-----|-----------------|
| 1 | Piston Pin Clip |
| 2 | Piston |
| 3 | Piston Pin |
| 4 | Connecting Rod |
| 5 | Woodruff Key |
| 6 | Piston Ring |

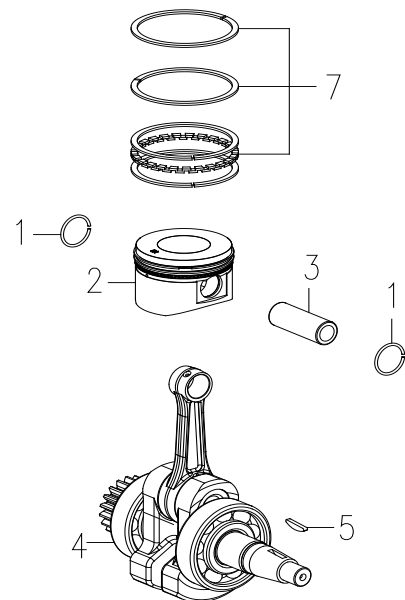

FIG. B CRANKSHAFT PISTON

Parts Diagram

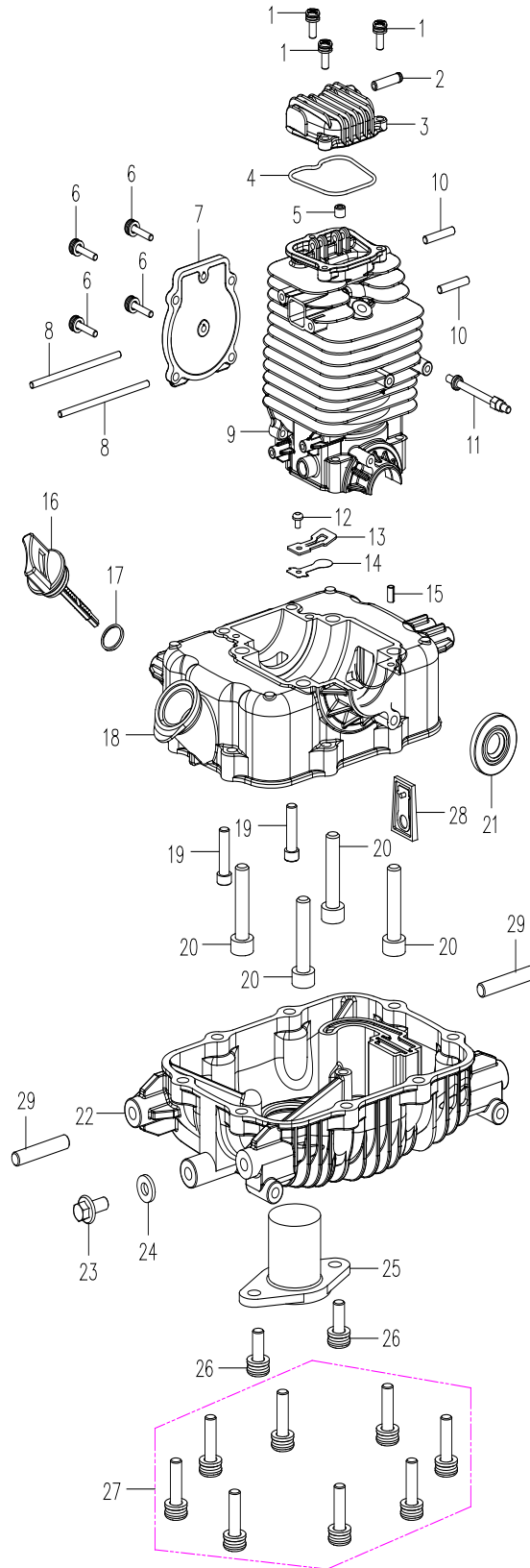

FIG. A CRANKCASE ASSY

FIG. C CAMSHAFT

| No. | Description |
|-----|----------------------------------------------------------------------------------------|
| 1 | Tappet |
| 2 | Lower Rocker |
| 3 | Pin 7 g6×39 |
| 4 | Rocker Bush |
| 5 | Cam Combination + Decompression of the pin + Torsional spring + Cover for cam |
| 6 | Camshaft |
| 7 | Upper Rocker |
| 8 | Valve Spring Seat |
| 9 | Valve Spring |
| 10 | Intake Valve |
| 11 | Exhaust Valve |

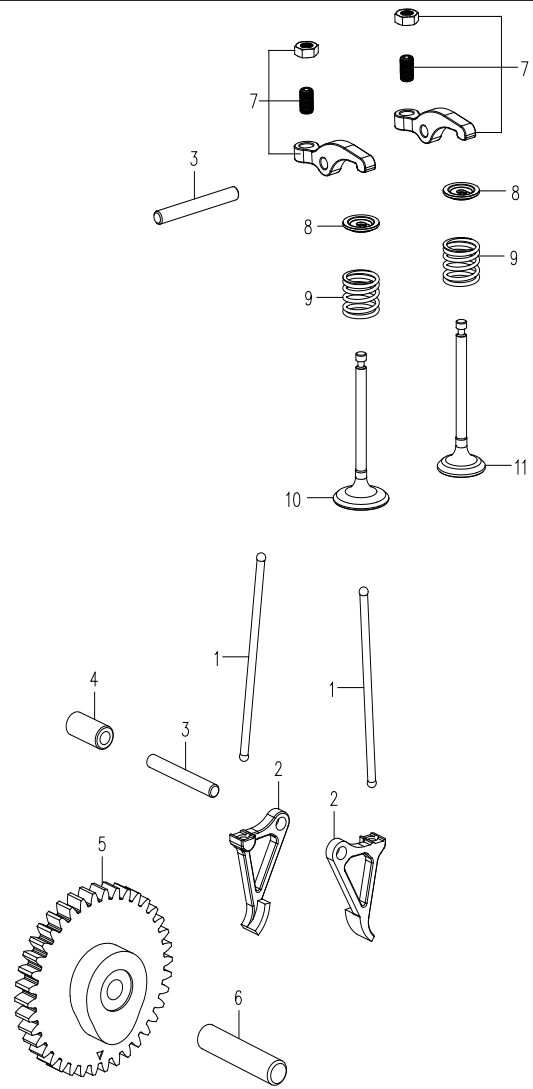

FIG. D LUBRICATION SYSTEM

| No. | Description |
|-----|---------------------------|
| 1 | Respiratory Tube |
| 2 | Outlet Tube |
| 3 | Pipe Hoop 9 |
| 4 | Hexagon Flange Bolt M5×16 |
| 5 | Deaerator |
| 6 | O Ring |

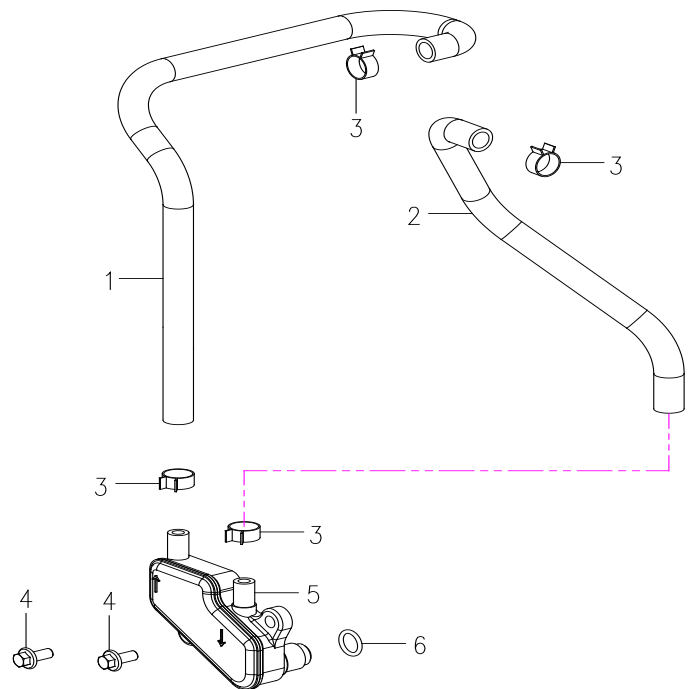

FIG. E AIR CLEANER

| No. | Description |
|-----|------------------------------------------------------------------------------------------------|
| 1 | Hexagon Flange Bolts M5 |
| 2 | Air Cleaner Bush |
| 3 | Air Cleaner Assy. +Cover of Air Cleaner Assy. +Foam/sponge +Inner Hexagon Screw M6×12 |
| 4 | Air Cleaner Gasket |
| 5 | Carburetor Gasket |
| 6 | Insulation Board Components |
| 7 | Insulation Gasket |
| 8 | Tap Screw ST4.8×16-F.H |

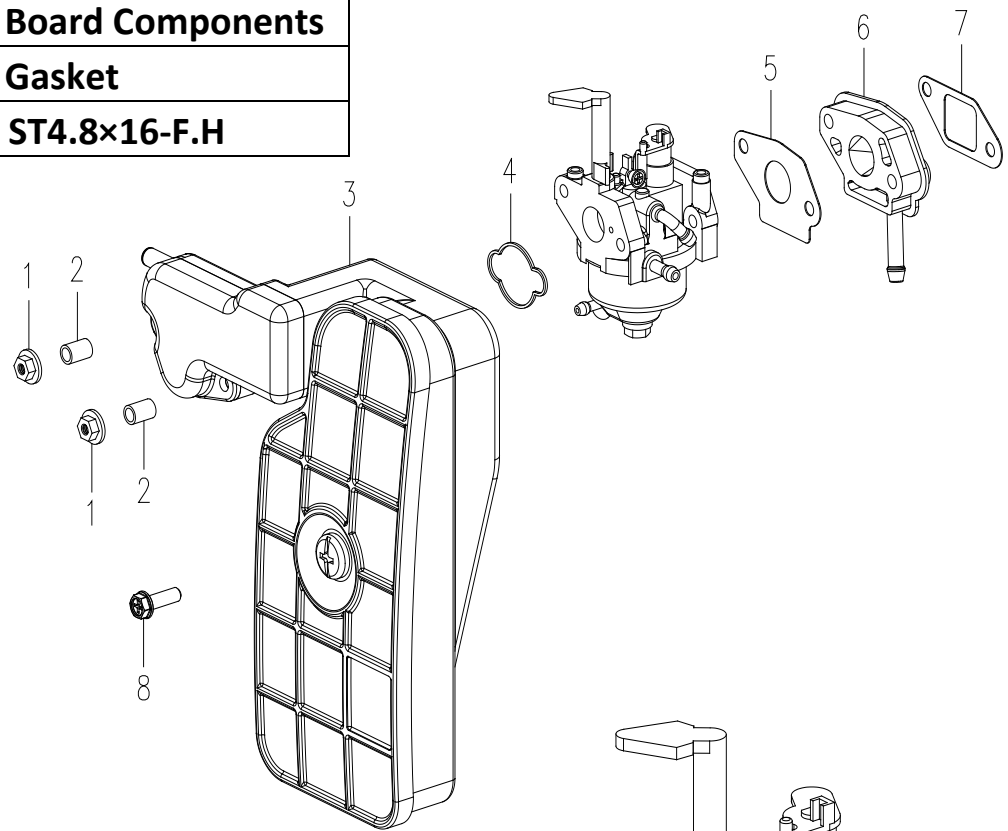

FIG. F CARBURETOR

| No. | Description |
|-----|------------------|
| 1 | Carburator Assy. |

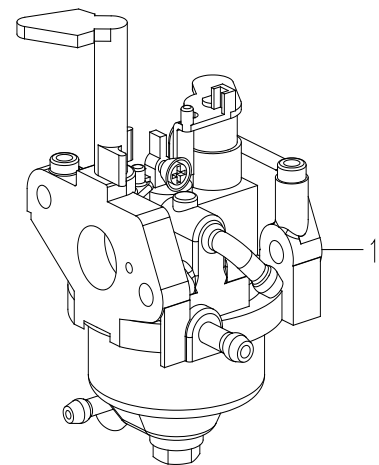

FIG.G RECOIL STARTER

| No. | Description | No. | Description |
|-----|------------------------------|-----|--------------------------------------------|
| 1 | Wire Clip | 8 | Starting Hub |
| 2 | Cylinder Head Cover Shroud | 9 | Inner Hexagon Screw M6×12 |
| 3 | Oil Filler Hole Airproof Pad | 10 | Fan Volute |
| 4 | Air Guide Sleeve A | 11 | Hexagon Flange Nut M5 |
| 5 | Air Guide Sleeve B | 12 | Hexagon Flange Bolts M5×25 |
| 6 | Tap Screw ST4.8×16-F.H | 13 | Starting Hub |
| 7 | Rubber Cover | 14 | Recoil Starter Parts +Handle +Fender |
| 8 | Cooling Fan | 15 | Hexagon Flange Bolts M6×12 |
| 9 | Wire Clip | | |

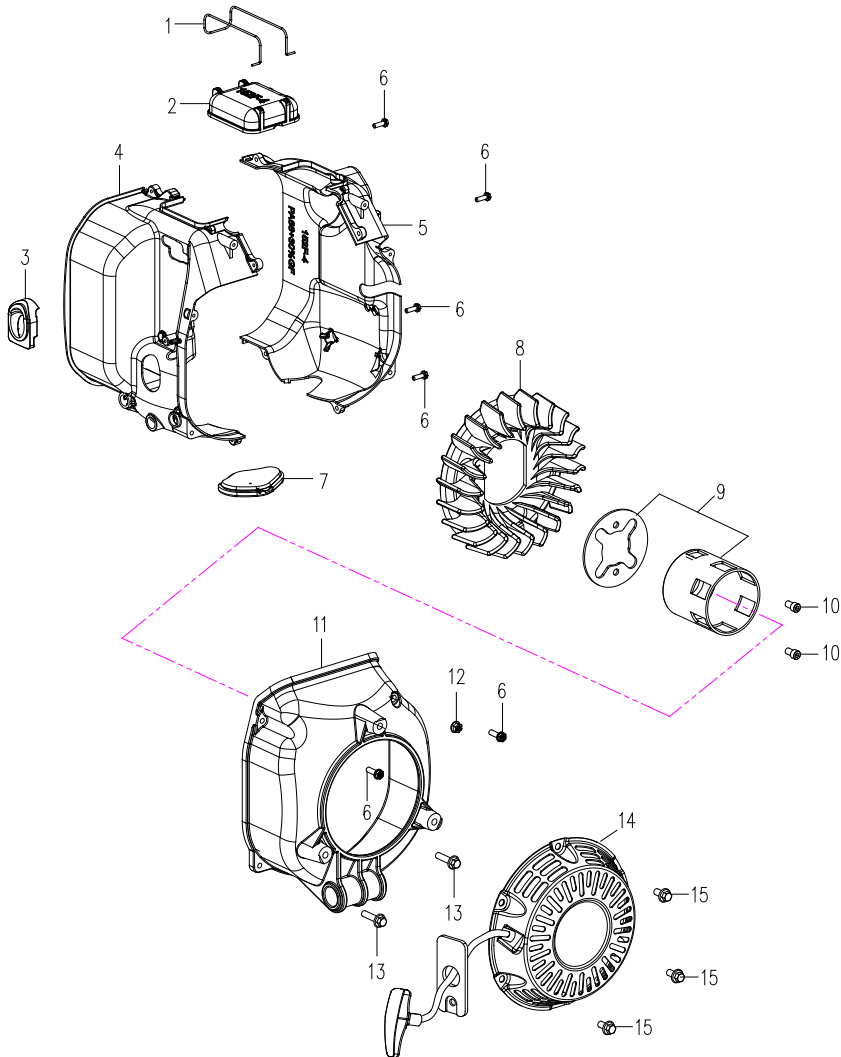

FIG.H MUFFLER

| No. | Description | No. | Description |
|-----|----------------|-----|-----------------------|
| 1 | Bolt M6×50 | 5 | Muffler Pipe Gasket |
| 2 | Bolt M6×80 | 6 | Muffler Pipe |
| 3 | Muffler Assy. | 7 | Washer 6 |
| 4 | Muffler Gasket | 8 | Hexagon Flange Nut M6 |

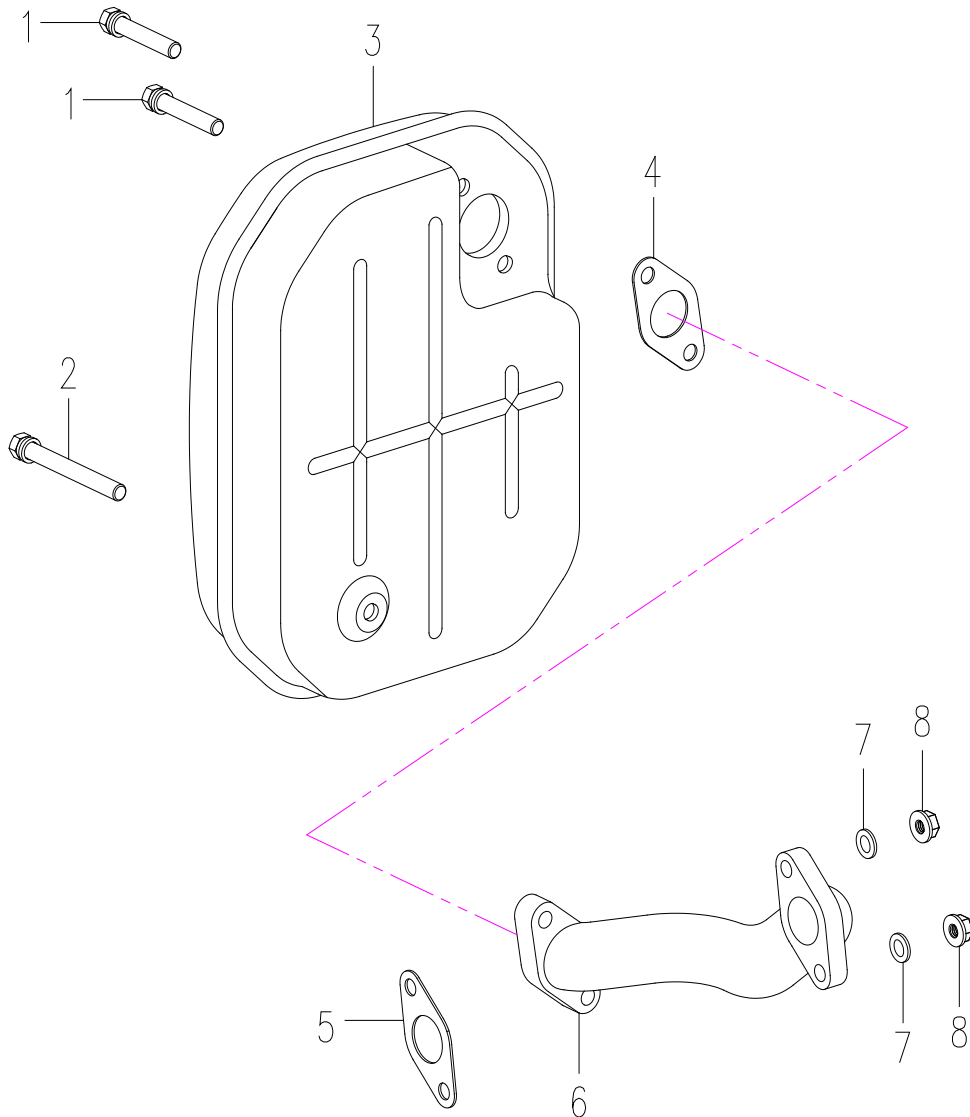

FIG.I GENERATOR

| No. | Description | No. | Description |
|-----|-----------------------------------|-----|----------------------------|
| 1 | Stator 1.7KW 420V 580Hz + bushing | 7 | Hexagon Flange Bolts M5×12 |
| 2 | Washer 5 | 8 | Tap Screw ST4.8×25-F.H |
| 3 | Hexagon Flange Bolts M5×30 | 9 | Ignition Coil |
| 4 | Rotor | 10 | Spark Plug A5RTC |
| 5 | Hexagon Flange Nut M12×1.25 | 11 | Ignition Coil Cap Seal |
| 6 | Trigger | | |

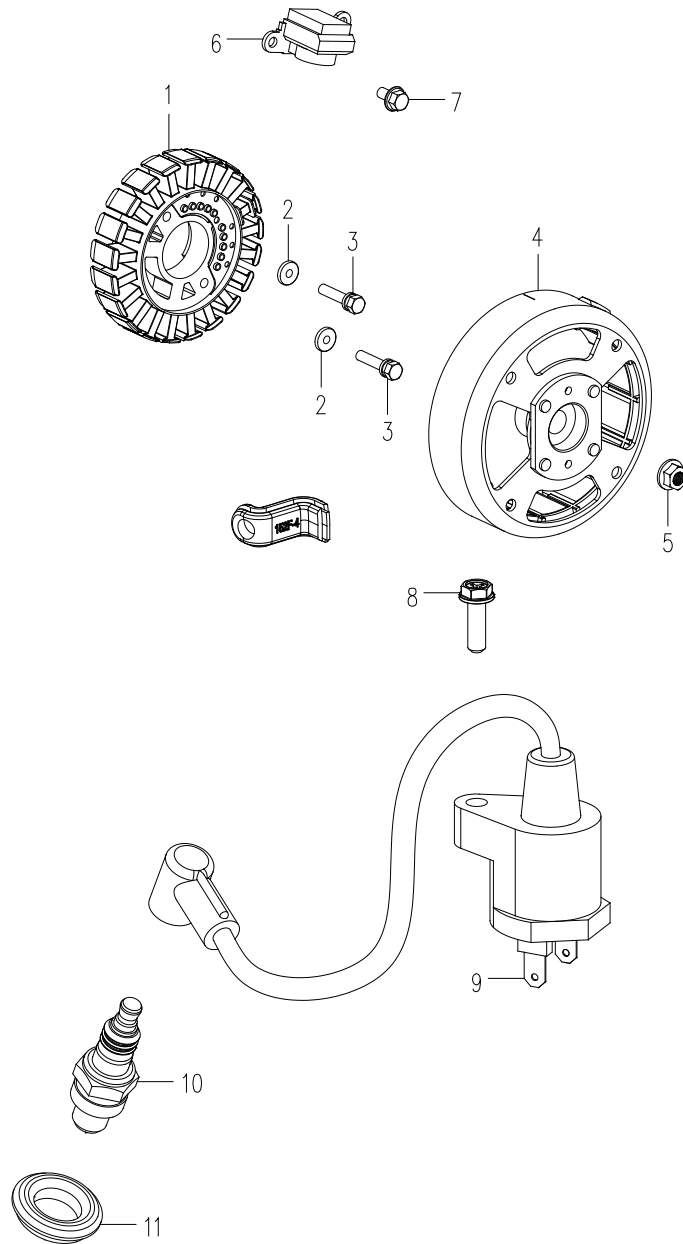

FIG.J FUEL TANK

| No. | Description | No. | Description |
|-----|---------------------------------|-----|----------------------------|
| 1 | Fuel Tank Cap Assy. | 12 | Fuel Cock Knob |
| 2 | Fuel Tank Port Rubber | 13 | Fuel Lubricator |
| 3 | Fuel Tank Filter | 14 | Fuel Pump |
| 4 | Fuel Tank | 15 | GasketGB/T96 φ4 |
| 5 | Fuel Tank Side Pad | 16 | Tap Screw GB/T845 ST4.0×19 |
| 6 | Fuel Outlet Filter | 17 | Tap Screw GB/T845 ST4.8×13 |
| 7 | Clamp Ø11 | 18 | Clamp Ø8 |
| 8 | Single-head Expansion Fuel Hose | 19 | Fuel Hose (4-8) -160 |
| 9 | Clamp Ø9 | 20 | Fuel Hose (5-10) -80 |
| 10 | Fuel Cock | 21 | Fuel Hose (5-10) -230 |
| 11 | Fuel Hose (5-10) -90 | 22 | Fuel Filter |

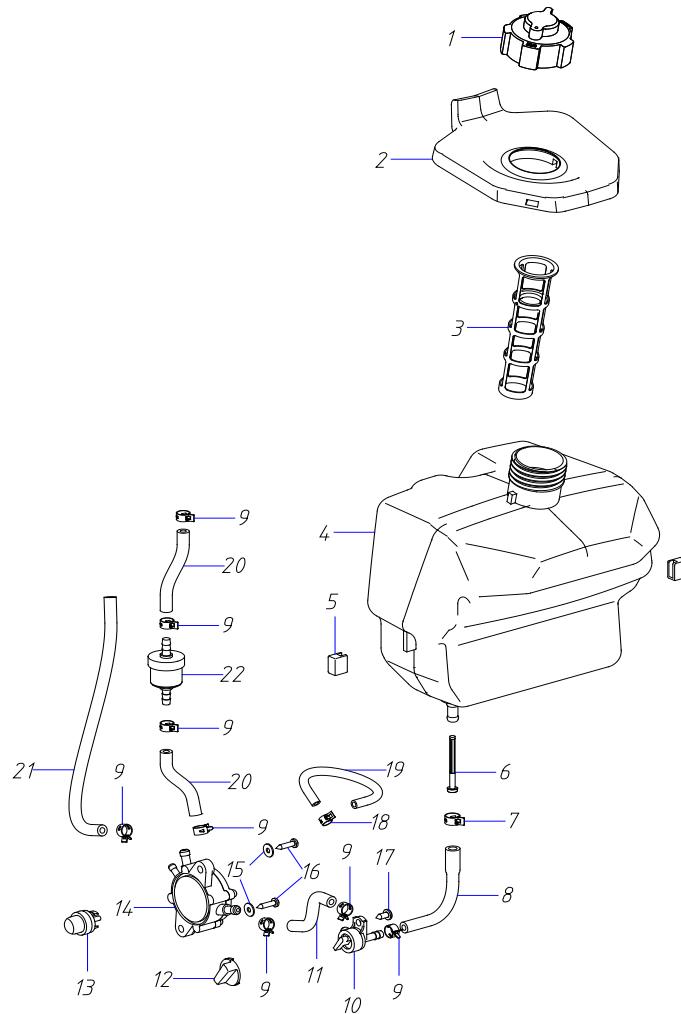

FIG.K SHELL

| No. | Description | No. | Description |
|-----|----------------------|-----|-------------------------------|
| 1 | Muffler Cover | 13 | Panel Box |
| 2 | Muffler Cover Seal | 14 | Rubber Shock Absorber long |
| 3 | Right Cover of Shell | 15 | Engine Holder |
| 4 | Left Cover of Shell | 16 | Rubber Shock Absorber short |
| 5 | Left Side Cover | 17 | Tap Screw GB/T845 ST4.8×9.5-F |
| 6 | Upper Cover | 18 | Tap Screw GB/T845 ST4.8×13-F |
| 7 | Right Side Cover | 19 | GasketGB/T96 φ5 |
| 8 | Rubber of Choke | 20 | Hexagon Flange Bolt M6×120 |
| 9 | Fastener | 21 | GasketGB/T96 φ6 |
| 10 | Edge Protection | 22 | Flange Lock Nut GB/T6187 M6 |
| 11 | Rubber Pad Φ6×Φ16×10 | 23 | Rubber Pad Φ6.5×Φ16×2 |
| 12 | Vibration Absorber | 24 | Panel Box |

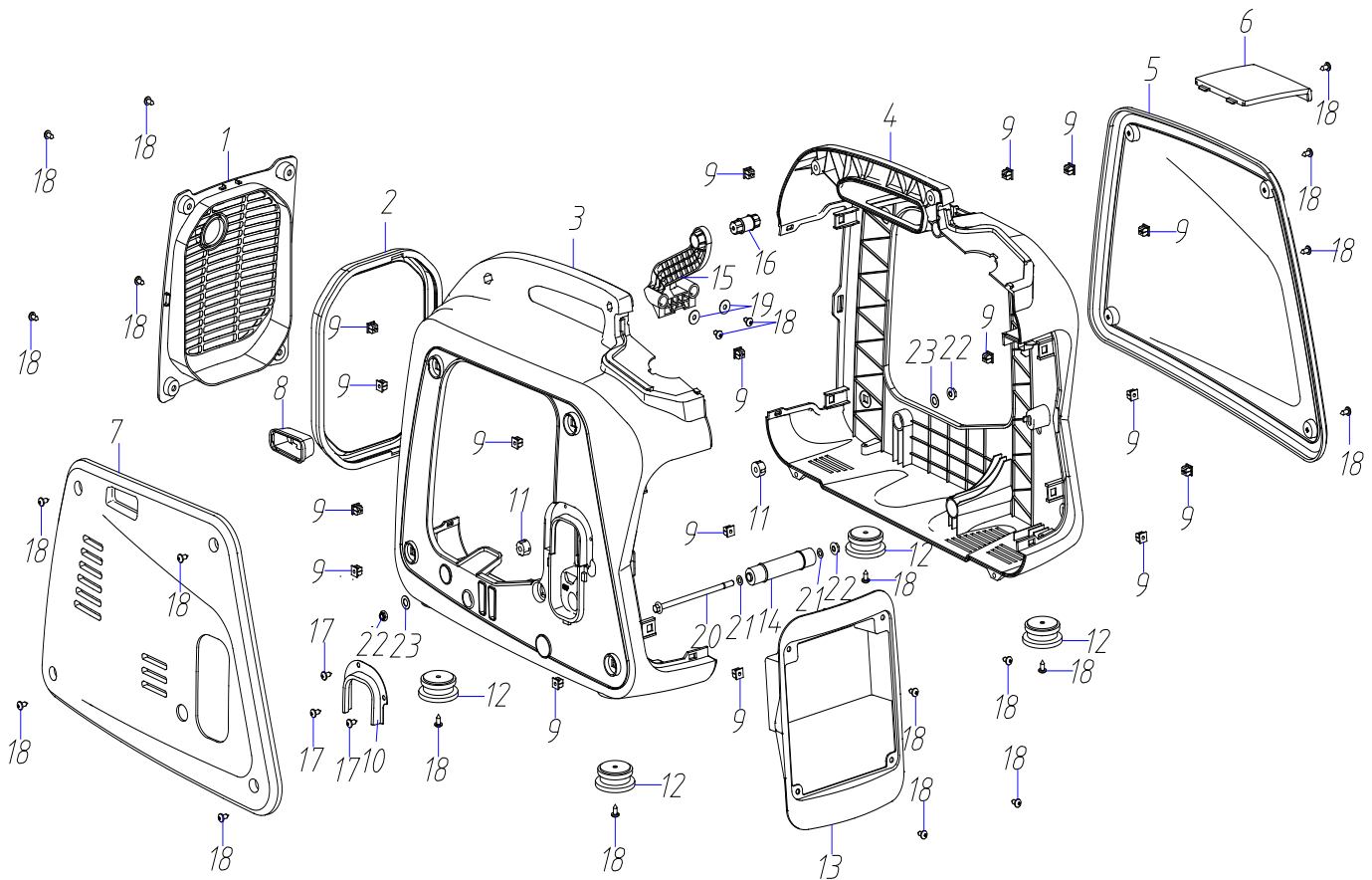

FIG.L GOVERNOR

| No. | Description |
|-----|----------------------|
| 1 | Drive Arm |
| 2 | Stepper Motor Holder |
| 3 | Screw M4×12 |
| 4 | Screw M3×8 |
| 5 | Stepper Motor Assy. |
| 6 | Drive Arm Spring |

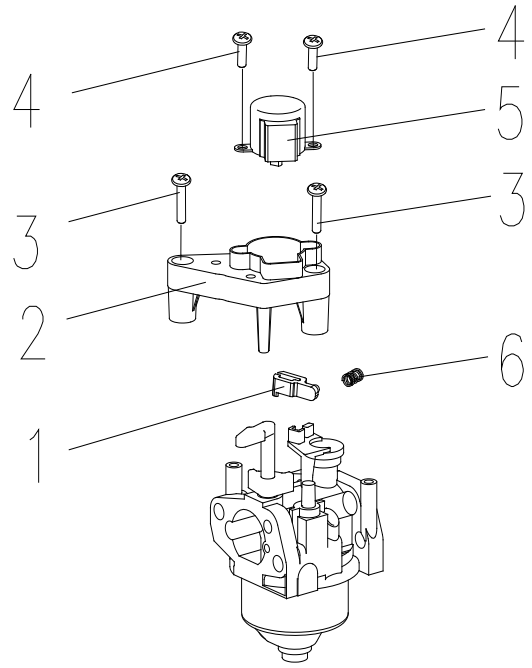

FIG.M INVERTER

| No. | Description |
|-----|--------------------------|
| 1 | Screw GB/T9074.4 M5×12 |
| 2 | Inverter 1.7kw 230V 50HZ |
| 3 | Inverter Gasket |

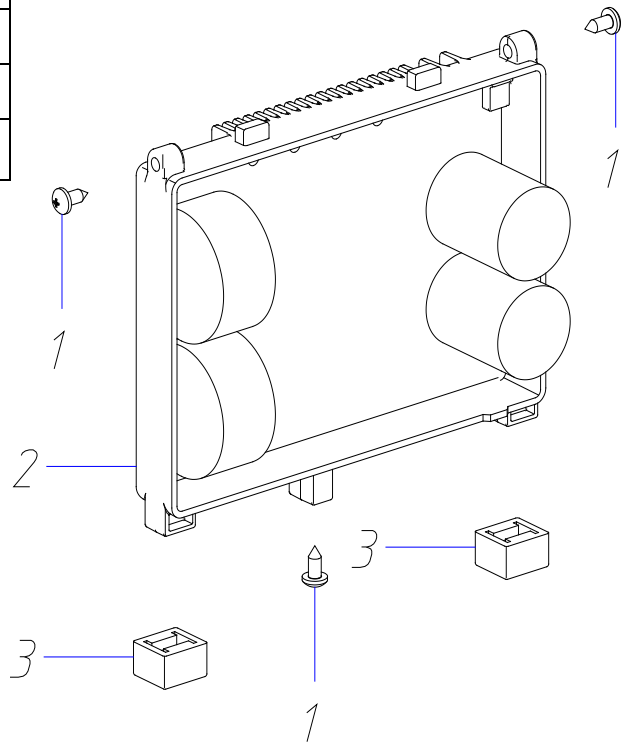

FIG.N CONTROL PANEL

| No. | Description | No. | Description |
|-----|----------------------------|-----|---------------------------------------|
| 1 | Cross Pan Head Screw M5×16 | 12 | Flat Washer GB/T97 φ5 |
| 2 | Ignition Controller | 13 | Spring Washer GB/T93 φ5 |
| 3 | Overload Protector 6A | 14 | Hexagon Nut GB/T6170 M5 |
| 4 | Cross Pan Head Screw M5×16 | 15 | European Socket |
| 5 | Rectifier KBPC3502 | 16 | Tapped Screw GB/T819 M4×12 |
| 6 | Hexagon Flange Nut M4 | 17 | Boat Switch |
| 7 | Flange Bolt GB/16674 M5×16 | 18 | DC Charging Socket |
| 8 | Lock Gasket GB862.2 φ5 | 19 | Water-Proof Cap of Overload Protector |
| 9 | Panel Components | 20 | Water-Proof Cap of Boat Switch |
| 10 | Panel Sticker | 21 | Screw M5×8 |
| 11 | Hexagon Flange Nut M5 | | |

